

# CRAFTSMAN

The Corps of Royal Australian Electrical and Mechanical Engineers

ISSUE NO. 51

SUMMER 2003/4



# 55



RAEME

10 November 1948-2003

## EDITORIAL BOARD

### EDITOR:

MAJ RODNEY BOLT  
MAJ GRAHAM ANDERSON

### EMAIL

rodney.bolt@defence.gov.au

## FOR NEXT ISSUE

Articles should be sent to:  
The Editor

The RAEME Craftsman  
S02 Corps RAEME  
LCSC, ALTC  
Milpo, Bandiana 3694

### DEADLINE

15 March 2004

Please note: Photos should be in colour if possible, with caption included; if sent on disk they need to be scanned in at 300dpi and saved as JPEG or TIFF. Save your text in Microsoft Word. Send us your disk and photos and we'll take it from there.



Unit 36a, 1a Coulson Street  
Erskineville NSW 2043  
PO Box 1097,  
Waterloo DC, NSW 2017  
Telephone: (02) 8596 8600

PERCIVAL PUBLISHING

## DISCLAIMER

The views expressed in this journal are the personal views of the authors, and unless otherwise stated, do not in any way reflect RAEME policy.

The attention of advertisers is drawn to the Trade Practices Act 1974 and the provisions in the Act which apply to advertising. It is not possible for the Corps of Royal Australian Electrical and Mechanical Engineers to ensure that the advertisements which are published in this magazine comply in all respects with the Act and the responsibility must therefore be on the person, company or advertising agency submitting the advertisement for publication. Percival Publishing and RAEME reserve the right to refuse any advertisement without stating the reason. All original material produced in this magazine remains the property of the publishers and cannot be reproduced without authority. No responsibility is accepted for incorrect information contained in advertisements or editorials.

# RAEME CRAFTSMAN

The Corps of Royal Australian Electrical and Mechanical Engineers

ISSUE NO. 51

SUMMER 2003/4

# crafty contents

Cover: 55 Years AEME/RAEME

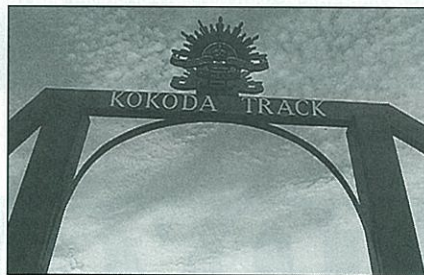

## REGULAR ITEMS

Head of Corps	3
Deputy Head of Corps	4
Biography – Deputy Head of Corps	5
Corps RSM	7
Reports	8
Vale	14
Acknowledgements	16
Feature Article	32
Unit Jottings	43

## ARTICLES

M113 AS3/AS4 – The Upgrade is finally upon us .....	18
M816 Wrecker Reborn .....	20
Colonel F B Oldfield, the first CO of the Army Apprentices School .....	22
Army Museum Bandiana ... ..	24
Basic Recovery Course 0003 .....	26
Army Personnel Agency – Townsville ....	28
AUSBATT 8 – Story of the RAEME flag ...	29
The Centurion Armoured Recovery Vehicle in RAEME Service .....	37

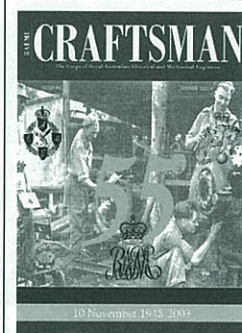
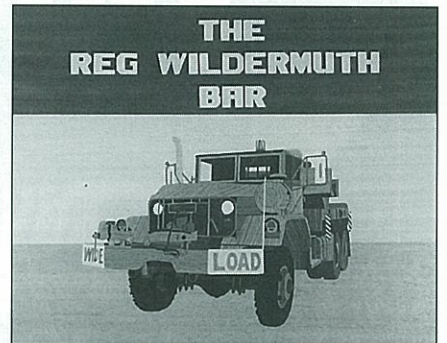

## 55th Anniversary

On 10th November 1948 His Majesty King George VI honoured AEME and several other corps by the granting of the title Royal. Australian Army Order 99, of 31st December 1948, promulgated the following:  
Grant of the title 'Royal' to Certain Corps of the Australian Military Forces. In recognition of their services during World War II, His Majesty the King has given approval to the granting of the title "Royal" to the undermentioned Corps etc of the Australian Military Forces, whose designations will, in future, be as follows:  
The Royal Corps of Australian Electrical and Mechanical Engineers  
The corps cipher was first mentioned at the Corps Committee meeting held in 1969. Approval was granted in 1975 and Corps Instruction number 5 (Apr 1975) was written to regulate its use and dimensions.

# 1000 BULLDOGS IN THE FLEET



The Australian Defence Force has a long association with Mack Trucks Australia. Originally using the Mack NR models during World War II, the Australian Defence Force has in recent years expanded its fleet of Mack trucks to exceed 1000.

This partnership continues, with Mack Trucks Australia having converted over 924 Army trucks to airbag suspension, and a further 280 to twistlock fittings.

So, when you're after trucks with proven capability and backed with the best support, there's only one name you can rely on - Mack!



[www.macktrucks.com.au](http://www.macktrucks.com.au)  
Ph: (07) 3718 3500 Fax: (07) 3718 3392

Contact Shane Hodby for all your defence needs 0411 096 661

M A C - W E ' R E O N T H E M O V E

20% OFF  
ALL TOYOTA  
ACCESSORIES

# GET YOUR TOYOTA 4WD COVERED IN STUFF.

HURRY IN  
OFFER APPLIES  
WHILE STOCKS  
LAST

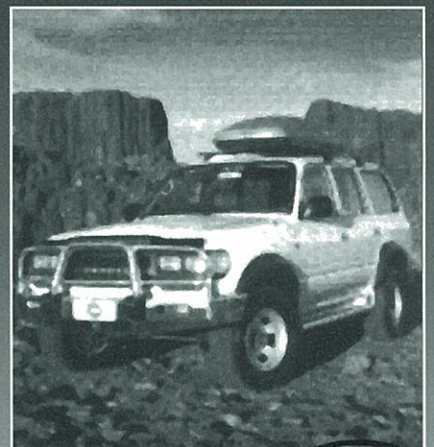
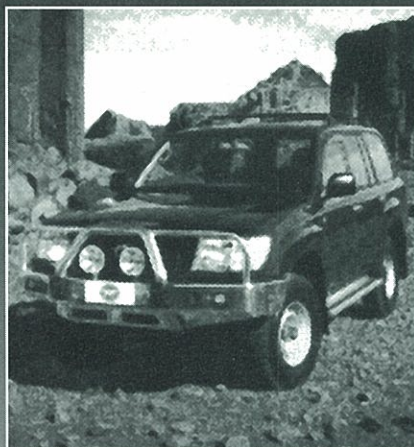
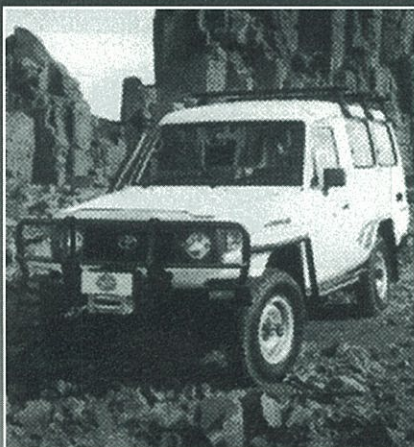

To keep your Toyota 4WD as reliable as the day it left the showroom, rely on Genuine Toyota 4WD accessories. We can help you with everything from bullbars to sidesteps, roof racks to driving lights. And because we only supply Toyota Genuine Accessories, we'll cover your Toyota in the right stuff. Just give us a call.



**WARREN  
TOYOTA**

TODMAN ROAD, WARWICK FARM, NSW 2170

**Phone: 9828 8999**

# introducing head of corps

## Xmas Message December 2003



*Head of Corps RAEME –  
Brigadier David McGahey, CSC*

craftsmen, artificers and engineers to maritime, air and ground equipment on ADF operations has been universally endorsed by all levels of command as exemplary.

On the home front, we have seen a number of changes to the way the Corps is structured, operates and is organised. In part this is driven by the relentless change of technology, a general upgrading of ADF equipment and by the irresistible pressures to make the Defence dollar go further. This year we have admirably faced the challenges of Technical Mastery; the Technical Regulatory Framework; the DIDS Implementation, the Kinnaird Review and the Upgrade and Implementation of the SDSS-MIMS Maintenance Module. Many of these changes although inevitable and necessary for

our future, have at times been difficult to accept, however, the constant note in a sea of change has been the dedication and professionalism of the men and women who selflessly serve and proudly wear the cap badge of RAEME.

On a personal note, I would like to make special mention of my own team in the RAEME HOC cell who have gone the extra yard to ensure that nearly all units of the Corps have been visited, your issues listened to and that our organisational and Corps needs are brought to my attention and addressed into the future.

Finally, my thanks for an excellent 2003, to you and the families of RAEME a happy and holy festive season, safe journeys and good soldiering in 2004.

*Arte Et Marte*

**David McGahey**

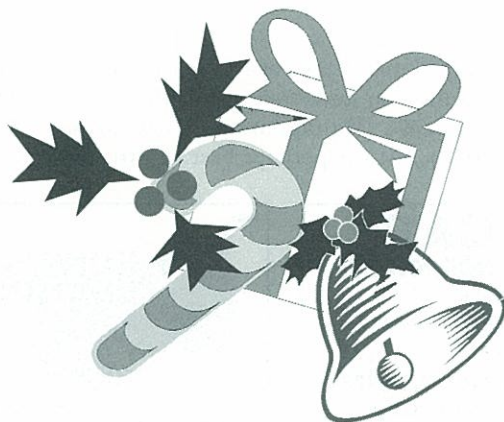

# message *from* deputy head of corps

*Deputy Head of Corps  
Lieutenant Colonel David A. Creagh*

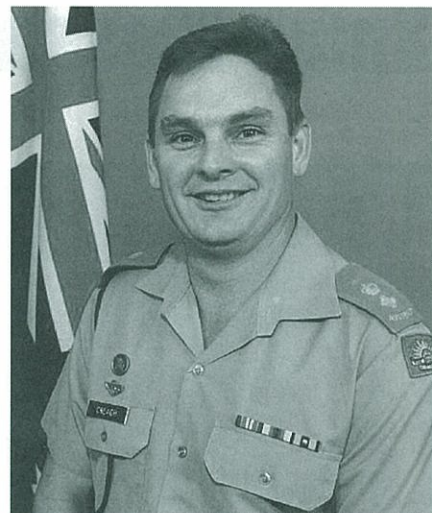

I like most of you am somewhat surprised at how quickly 2003 has drawn to a close. I suspect that as the *RAEME Craftsman* hits the streets many of you will either be in 'wind down' mode, on leave or about to proceed on a new posting!

I have just returned from a visit to 5 and 8 Bde, SME, 3 RAR, 4 RAR (Cdo) and 17 Const Sqn. As has been the case throughout the year, I remain impressed with the professionalism and dedication of our many Unit Wksp and TSSUs! The usual range of sticky questions arose and where we have taken them 'on notice' feedback will be forthcoming in the last *RAEME Newsletter* for 2003. We hope to have this on the streets by early December.

During our visit to the Eastern Region, we travelled to Adamstown (Newcastle) to attend the 8 CSSB Fd Wksp parade night. During this visit the Corps RSM and I were fortunate to be able to speak with a number of Army Apprentices who are undertaking trade

training as part of the Army Reserve Apprenticeship Scheme. This scheme continues to go from strength to strength and will be 'rolled out' to a number of other 2 Div Bdes as well as 11 CSSB in the New Year.

By now most of you will have heard that the Corps Seminar was an outstanding success. We had over 200 Officers, Warrant Officers and SNCOs present and it proved to be an ideal opportunity to catch up with old friends and to discuss the many issues affecting the Corps. The RAEME HOC cell is currently finalising the annual brief (including a synopsis of the major seminar outcomes) we are required to present to CA each year. The HOC will keep you abreast of developments once we have presented the brief and received feedback.

On a training specific note I can now confirm that Army has recently signed a new five-year trade-training contract with Scientific Management Associates (SMA). SMA is perhaps best known for

its role as the in-house contractor for the delivery of trade training for the RAN at HMAS Cerberus and for its work with Defence contracts, the most notable being its involvement in the new ANZAC class of warship. December 2003 also marks a significant milestone in that we will graduate from MSD, ALTC the first batch of ECN 421s. Exciting times indeed!

We intend to continue with our practice of visiting as many regions as practicable in each calendar year. For those of you in 1, 4 and 13 Bdes and Oakey I look forward to catching up with you in the first half of 2004. I hope to also visit 3 Bde and 7 Bde at some stage during 2004.

For those of you proceeding on leave and/or posting, good luck and God Speed! I wish every member of the Corps and their families a safe and merry festive break.

*Arte et Marte*

**David Creagh**  
Deputy Head of Corps

## **WE CARE LAWN CARE**

**DOMESTIC • COMMERCIAL • BODY CORPORATE**

- \* Lawns Mowed & Whipper Snipped
- \* Trees Trimmed & Removed \* Rubbish Removed
- \* Irrigation \* Pensioner Discounts

Contact Tony: 0411 709 171 – 4725 6270 Fax: 4725 6123

Email: [wecarelawnca@austranet.com.au](mailto:wecarelawnca@austranet.com.au)



- DOMESTIC • COMMERCIAL & INDUSTRIAL
- SPRING & GENERAL CLEANING
- REAL ESTATE INSPECTION & CLEAN

Reliable with 15 Years Experience

Contact Edna or Andrew

**8985 3831 – 8948 5345**

Email: [ajohnston@ais.net.au](mailto:ajohnston@ais.net.au)

# biography

## deputy head of corps

Lieutenant Colonel David Creagh is the Commanding Officer/Chief Instructor of Materiel Support Division. Lieutenant Colonel Creagh is a Queenslander who entered the Royal Military College, Duntroon in January 1981. He graduated in December 1984 into the Royal Australian Electrical and Mechanical Engineers and subsequently completed a range of regimental appointments including service with the 1st Armoured Regiment and The 2nd/3rd Field Engineer Regiment.

Following a two year instructional appointment at Corps Training Wing, Lieutenant Colonel Creagh was posted to Headquarters 1st Division. In January 1993 and whilst posted to the Divisional headquarters, Lieutenant Colonel Creagh deployed to Somalia as part of Operation Solace as the Staff Officer Grade Two Logistics. On return to Australia, he was posted to the 3rd Brigade Administrative Support Battalion as the Officer Commanding of the Field Workshop. Later postings included Headquarters Training Command, attendance at the Royal Australian Navy Staff College and Headquarters Logistic Support Force. Whilst posted to the Logistic Support Force, Lieutenant Colonel Creagh deployed to Iraq as a member of one of the United Nations Special Commission Inspection Teams.

In 1998 Lieutenant Colonel Creagh was selected for and subsequently posted to the Australian Permanent Mission to the United Nations as the Assistant Defence Attache. On his return to Australia, Lieutenant Colonel Creagh was posted to Army Headquarters as the Staff Officer Grade One Equipment Management. He has been in his present appointment since January 2003.

Lieutenant Colonel Creagh holds a Master of Professional Studies in Human Resource Management, a Bachelor of Arts Degree from UNSW and a Graduate Diploma in Management Studies.

During the course of his military career Lieutenant Colonel Creagh has been awarded a Land Commanders Commendation for his efforts during Operation SOLACE and a Chief of Army Commendation for his efforts as a staff officer at Army Headquarters.

Lieutenant Colonel Creagh is married to Sue, a midwife. They have three children, two daughters, 12 and 10 and a son, 6. A rugby enthusiast, he enjoys reading, history and keeping fit.

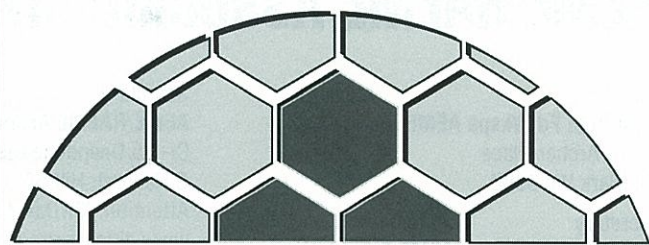

## HONEYCOMBES

CARS & 4WDS

**PROUD TO SUPPORT THE  
AUSTRALIAN  
DEFENCE FORCES**

**Full range of  
quality new and  
used vehicles**

\* **FAST AFFORDABLE  
FINANCING**

\* **231 POINT QUALITY  
INSPECTION**

\* **7 DAY EXCHANGE  
GUARANTEE**

**WE BUY CARS and  
4WD'S for CASH**

**Ph: 8947 3888**

**Website:**

[www.honeycombescars.com.au](http://www.honeycombescars.com.au)

**E-mail:**

[dwn@honeycombescars.com.au](mailto:dwn@honeycombescars.com.au)

**Address:**

544 Stuart Highway, Winnellie  
(next to Darwin Showgrounds)

# AEME RAEME Associations and Kindred Organisations

Secretary  
**2/1st Aust Fd Wksp AEME Association**  
C/- 10 Archer Place  
Mill Park Vic 3082

Secretary  
**2/2nd Aust Fd Wksp AEME Association**  
C/- Unit 6/35 Clowes Street  
South Yarra Vic 3142  
Attention: Mr William Tolhurst

Secretary  
**2/4th Bde Wksp AEME Association**  
C/- 729 Gilbert Road  
Reservoir Vic 3073  
Attention: Mr Ernest Deakin

Secretary  
**11th Aust Adv Wksp AEME Association**  
C/- 70 Clarendon Street  
West Coburg Vic 3058  
Attention: M Charles Kerwood

Secretary **126th/127th Aust Bde Wksp and Fd Park Association**  
C/- 26 Goodgoverns Street  
Mitcham Vic 3132  
Attention: Mr Allan Beasley

Secretary  
**127th Aust Bde Wksp and Fd Park AEME Association**  
C/- 129 Ellesmere Parade  
West MacLeod Vic 3085  
Attention: Mr Jim Hemperstal

Secretary  
**The RAEME Association (Vic) Inc.**  
C/- Oakleigh Barracks  
1318 North Road  
Oakleigh South Vic 3167  
Attention: Mr Ron Clifford  
www.nex.net.au/users/vraeme  
(under construction)

**RAEME Vietnam Association (Vic)**  
30 Wilkinson Drive  
Wodonga Vic 3690  
Attention: Mr Brian Kelly  
Email: brian1939@hotmail.com

Secretary  
**RAEME Association (NSW) Inc**  
PO Box 463,  
Moorebank NSW 1875  
Attention: Mr Chris Davis  
www.raemensw.com  
artvehwo1@bigpond.com

Secretary  
**AEME/RAEME Association (ACT)**  
C/- 5 Barnes Place  
Charnwood ACT 2615  
Attention: Mr Lyell Wedd  
http://members.austarmetro.com.au/-  
Lwedd/raeme/

Secretary  
**RAEME Association (Qld)**  
PO Box 11, Cannon Hill Qld 4170  
www.raemeqld.org

Secretary  
**AEME/RAEME Association SA Inc.**  
C/- 25 Deepdene Crescent  
O'Halloran Hill SA 5158  
Attention: Mr David Turner  
www.diggerz.org/users/raasa

Secretary  
**RAEME Association (SA) Branch**  
C/- Site 275 Hillier Park, Hillier Road  
Hillier SA 5116  
Attention: Mr Lionel Clayton

Secretary  
**RAEME Association WA Inc.**  
PO Box 186  
Bayswater 6053  
Attention: John Curtis  
www.redbackwebs.com.au/raemewa

Secretary  
**RAEME Vietnam Association SA**  
C/- 33 Kanimbla Way,  
Morley WA 6064  
Attention: Mr Gary Whykesi

Secretary  
**RAEME Corps Committee (WA)**  
C/- 11 Celestine Street,  
Wanneroo W.A. 6065  
Attention: Mr Don Horsely

Secretary  
**AEME/RAEME Association (TAS)**  
C/- 3 Homer Avenue,  
West Moonah TAS 7009  
Attention: Mr Graham O'Donnell OAM

Vice President/Secretary  
**RCEME Association**  
C/- RRI Stella Amherst Island  
Ontario Canada KOH2S0  
Attention: Mr Rick Morgan

Secretary  
**REME Association  
Regimental Headquarters REME**  
Issac Newton Road  
Aborfield Reading  
RG29NJ UK  
Attention: Capt G.M. Anderson RL

## THE RAEME ASSOCIATION (Victoria) INCORPORATED

The RAEME Association has a primary role to foster and develop spirit and tradition throughout the RAEME Corps in Victoria and its Rural Areas. This is achieved by the Association through the involvement of members in social, military and Corps events in Victoria.

The Association is open to all ranks and membership is automatic for serving and exserving AEME/RAEME Corps and REME British Commonwealth Defence Force members are eligible for Association membership.

Entrance Fees: \$10.00 Annual Fees: \$15.00  
TOTAL \$25.00

Contact: The Secretary The RAEME Association (Vic) Inc.  
C/- Oakleigh Barracks 1318 North Road,  
OAKLEIGH SOUTH VIC 3167  
PH: (03) 9888 3359

or  
Albury/Wodonga  
**Brian Tingwell**  
RMB 1217A,  
Mahers Rd,  
Wodonga 3690  
Ph: (02) 6027 3402

Echuca/Shepparton  
**Harry Ross**  
22 Dobinson St  
Echuca 3564  
Ph: (03) 5480 6794

Ballarat/Daylesford  
**George Hepburn**  
24 Junction Rd  
Ballarat 3350  
Ph: (03) 5331 3153

Bendigo/Castlemaine/Heathcote  
**Dave Field**  
10 McInnes St,  
Kangaroo Flat 3555  
Ph: (03) 5447 9422  
Mobile: 0419 524 035

Hoppers Crossing/Geelong  
**Rex Foord**  
598 Thompson Rd,  
Norlane 3214  
Ph: 5275 1728

Leopold/Anglesea/Portarlington  
**Lyal Butling**  
11 Oxley St,  
Portarlington 3529  
Ph: (03) 5259 3529

Berwick/Packenham/Warragul/  
Morwell/Traralgon/Sale  
**Bill Slegers**  
25 Main Neerim Rd, Drouin 3818  
Ph: (03) 5625 2232  
Mobile: 0419 136 149

Cranbourne/Korumburra/  
Welshpool/Foster  
**Kevin Moon**  
1 Hawkins St,  
Korumburra 3950  
Ph: (03) 5655 1545

# corps RSM report



*Corps RSM K. D. Packer*

It is with a large amount of regret that this is my last report as the Regimental Sergeant Major of the "Royal" Corps. I have been honoured to hold the position of the Corps' senior soldier for the past two years as it has given me the opportunity to have some input into the positive direction the Corps has gone in those two years.

There have been numerous issues that the Head of Corps Cell has tackled on behalf of the "Crafties", several of which we have had wins with. Two of the key changes this year that have been pleasing are the ownership of the Subject 2 for Corporal Course handed over to Training Command and the successful delivery of that course at Integrated Logistic Division (ILD) at ALTC and the renewal of interest in the Regimental Stream.

## **Subject 2 Corporal**

At the beginning of 2002, the corps had a significant backlog of soldiers awaiting Subject Two for Corporal. This was due to the increase in operational tempo within Land Command and the resulting reduction in manpower and resources to conduct these courses in the Land Army. The conduct of the Subject 2 Corporal Course was handed over to the RAEME Cell at ILD and with a revamp of the course content the pilot course was conducted early this year with the first of the courses kicking off on the 7 July. By the end of this year the cell will have completed five courses of

twenty students and the topics covered on the course will round out our tradesmen with the skills that they all require in order to become effective JNCOs.

The course also standardises the training taught to our soldiers and impresses the importance on how we go about our "Black Art" particularly in the field environment. And, yes, it is of relevance to the aviation side of the corps. The knowledge obtained from this course will ensure the safe conduct of conducting FRTs if properly applied during exercises and operations. The importance of having "RAEME aviation" input into this course has now seen the RAEME Cell manning increase with two aviation tradesmen on establishment to provide their expertise, input and provide continuity to the course.

## **Regimental Stream**

For the past two years I have pushed my regimental barrow around the Corps touting it's importance to the Corps and the Army. I have also impressed that leaving the trade for a stint at the regimental side of the Corps not only benefits the Corps but the soldiers who undertake the challenge. I view a regimental posting to ARTC as a further development of the other skills good junior and senior NCOs should possess. It also offers one of the few respite postings available to our tradesmen from the constant grind they are placed under in Land Command. It will still be a challenging posting but allows the soldier to recharge the batteries by being out mixing it with their peers from other corps and broadening their military and man management knowledge. Our tradesmen today see that their days of manag-

ing their soldiers first hand are limited and at the sergeant and warrant officer level they will be driving a desk inputting data into SDSS, extracting reports, and ensuring that the unit complies with the TRF. Those that go to a regimental position are not obliged to remain in that trade stream and can go back to their base trade without detriment to their career progression.

The Corps now has a strong base to start developing a structured regimental stream with the following positions now filled: a full complement of SGTs and CPLs at Kapooka, 2 SGTs at RMC, 1SGT at ADFA, 3 diggers on the Federation Guard and the ability to post sergeants and warrant officers to any of the logistic instructor positions at the various RTCs around Australia. We also have seen an increase in the number of RAEME CSM/SSMs back in our units.

I would finish by reminding the members of the corps in supervisory roles that the equipment we issue our tradesmen and the systems we introduce to capture data are just another tool in our tool box. The major asset we have is the guys and girls turning spanners. If we could only focus our attention more on them rather than on the implementation of new kit that we are not allowed to repair and on systems that capture data that we do not put to use.

## **Conclusion**

To you all, good soldiering and I wish you all the very best for your future careers and endeavours. I will not be that far away and will look forward to maintaining those friendships I have established within the Corps.

*Arte et Marte*

# reports

## SO2 Corps Report

By Major Graham Anderson

**A**s the festive season for 2003 fast approaches I would like to take this opportunity to summarise some of the HOC cell activities and to acknowledge and thank members of the Corps for their support. In addition there are a few activities that we are still in the process of finalising prior to the block leave period and post-ing cycle kicks in.

### Corps Seminar

The 2003 Corps Seminar was held at Bandiana over the period 16 – 17 Oct 03. The seminar theme was 'RAEME – Successes and Challenges'. The event was well supported with over 200 Corps members in attendance. The seminar featured guest speakers from MINCOM and Tenix who provided very informative presentations on Industry in the Defence Environment. Throughout the course of the two days participants heard from a number of presenters on a broad range of topics and issues impacting on the Corps. The seminar provides a very important opportunity for members of

the Corps to be updated on issues and activities occurring within and impacting upon the Corps and at the same time contribute to the future shaping of the Corps. The seminar is to be conducted each year in October. Members of the Corps are encouraged to attend. In addition to the actual seminar a number of successful social events were included in the seminar program. These include the all ranks function, the annual Corps Officer Dinner, and the annual WO SNCO Dinner. The dinners and all ranks functions were very enjoyable and provided an excellent opportunity to renew old acquaintances. During the officer's dinner BRIG McGahey took the opportunity to formally farewell and acknowledge the significant contributions of BRIG Colin Sharp (outgoing HOC), COL Larry Foley (outgoing Representative Col Comdt), and COL Jack Wilson (outgoing Col Comdt Vic/Tas Region).

There was a comprehensive program of issues discussed over the two days. A more detailed summary of the seminar will be provided in the HOC Newsletter to be released this month. A comprehensive summary is also available on the Intranet Corps website, along with copies of presentations and photos from the dinners.

### Corps Port

The 2003 Corps Port was arranged by the HOC cell. This year's release, which includes a collectors miniature, is a fine Rutherglen selection which features BRIG Field (our first Corps Director) and lists all Corps Directors/Heads of Corps. The main distribution of port has occurred however a quantity is still available for \$15 per bottle from the HOC cell, POC is SO2 Corps, MAJ Graham Anderson, (02) 6055 4308, or [graham.anderson@defence.gov.au](mailto:graham.anderson@defence.gov.au).

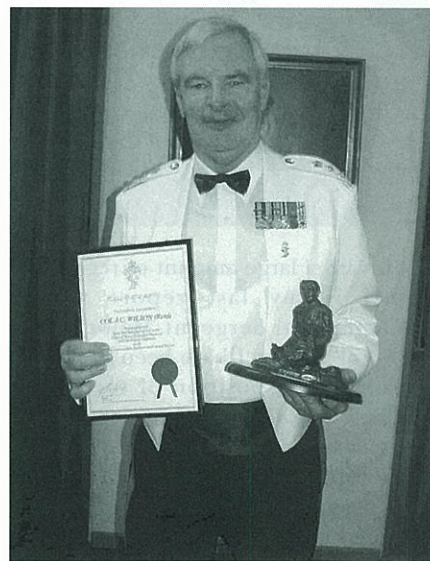

SO2 COL Jack Wilson

### Prince Philip Banner Miniature

Hopefully by now you would be aware of the limited release Prince Philip Banner Miniature. The 2003 'Foundation' issue of the miniature is limited to 200 and is currently available for order at \$160 each. Of the 200 there are only about 25 remaining for purchase so if you are interested you will need to act fast. Delivery is programmed for late December however that is yet to be confirmed and may carry over until after Xmas. Subsequent releases of the miniature (yet to be confirmed) will incur a 20 per cent price increase.

The framed miniature is a limited numbered series restricted to currently serving and ex serving members of the Corps. The miniature is a quality replica of the Prince Philip Banner. Each miniature will be individually certified and numbered within a limited numbered series. The size of the miniature is approx 240mm x 360mm. The POC for Banner miniatures is MAJ Graham Anderson, details above.



SO2 COL Foley and HOC

# Awards 2003

**LT Peter Jennings  
Memorial Award**



LT S. Cleggett – 5 Avn Regt

**ARA National Craftsman  
of the Year Award – STH QLD**

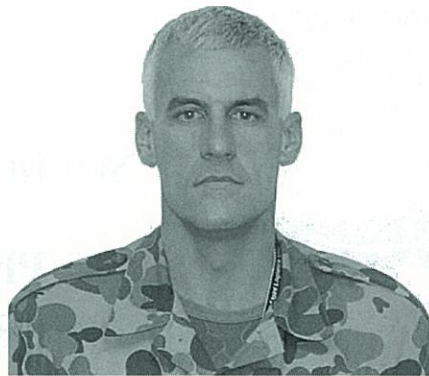

CFN G.D. Bird – 7 CSSB

**GRES National Craftsman  
of the Year Award**



CFN G.C. Jackson – 4CSSB

**Artificer Award**



SGT D. Kerschhat – 25/49 RQR

**ARA National Craftsman  
of the Year Award – NTH QLD**



CFN P. Crosby – 3 CER

**GRES Regional Craftsman of the  
Year Awards – Western Region**



CFN R.J. Denton – 13 CSSB

**Junior Regimental Award**



SGT N. R. Davis – B Sqn 3/4 Cav Regt



**BRIG Martins Encouragement Award**

SGT A. Edwards – 5 Avn Regt

**ARA National Craftsman  
of the Year Award**

CFN S.P. Geaney – 1 CER

**ARA Regional Craftsman  
of the Year Awards**

Northern Region  
CFN S.P. Geaney – 1 CER

VIC/TAS Region  
CFN G.C. Jackson – 4 CSSB

# Semi Trailer Specialist

## SPARE PARTS – for all makes

Suspensions • Turntables • Landing Legs • Lights  
• Signs • Load Restraint • Cleaning Products

## WORKSHOP SERVICES – including:

Smash Repairs • Air Bag Retrofits • Brake Mechanics  
• Steel and Aluminium Welding • Rebushing  
• Accessories and Refurbishments  
• Emergency Breakdown Service 24 Hours

# SXtrailers LTD

## SYDNEY

16-18 Riverside Road, Chipping Norton  
Phone: (02) 9755 3333 • Fax (02) 9725 6563  
Internet: [www.sxtrailers.com.au](http://www.sxtrailers.com.au)

Newcastle, Wagga and Tamworth

**FREIGHTER** **Maxi-CUBE** **SXtippers**



## Project Coordination

## MAJOR DEFENCE FORCE BUILDING CONTRACTORS

\* COMMERCIAL

\* INDUSTRIAL

\* NEW DEFENCE HOUSING PROJECTS

Phone: 3721 2800

Fax: 3721 2899

email: [brisbane@projectcoord.com.au](mailto:brisbane@projectcoord.com.au)

[www.projectcoordination.com.au](http://www.projectcoordination.com.au)



"Protecting the technology in your world"

15 Year's Experience

CALL US FOR ADVICE OR FOR A QUOTE

Specialising in the Supply, Install & Certification of:

- ⌚ Direct Lightning Strike Protection
- ⌚ Surge Protection for Power & Signal Lines
- ⌚ Earthing Systems
- ⌚ Consultaion & System Design

Ph: (02) 4587 5700 Fax: (02) 4587 5701

Email: [sales@ldu.com.au](mailto:sales@ldu.com.au)

## DSTechwrite

Technical Authors and Illustrators  
of User Handbooks  
Electrical & Mechanical Engineering Instructions  
(EMEs)  
Repair Parts Identification Lists  
Certified Distributor of **Mincom LinkOne**

Proud to be recommended contractors for the Australian Defence Forces

2/16 Mecklem St  
PO Box 298  
Strathpine Qld 4500

Ph: (07) 3881 3477  
Fax: (07) 3881 3579  
Mob: 0403 600 404

<http://www.dstechwrite.com.au> email: [info@dstechwrite.com.au](mailto:info@dstechwrite.com.au)

## LYNK DYNAMICS

Design & Manufacture Cable Assemblies  
ISO9001. Fully Army approved  
Recognise NSN's, CX-F, CX-G designators  
Currently producing for Power, Radio/Comms,  
ASLAV & Bushmaster  
New, service, repair/overhaul

Ph: (02) 9684 5755

Fax: (02) 9684 5700

Email: [lynk@bigpond.net.au](mailto:lynk@bigpond.net.au)

## HAULMARK TRAILERS

"A symbol of quality"

- Manufacturers of Specialised Road Transport Equipment
- Certified Quality Assurance to ISO 9001

For more information contact your nearest Haulmark Office:

BRISBANE

SYDNEY

DARWIN

Ph: (07) 3277 3666

Ph: (02) 9755 3877

Ph: (08) 8932 2626

# Army signs new five year technical trade training contract

**O**n 12 Nov 03, the Commandant of the Army Logistic Training Centre (ALTC), Colonel Garry Banister, AM and the Managing Director of Scientific Management Associates (SMA) Operations, Mr Owen Culley marked the commencement of a new contract for the delivery of technical trade training for the Australian Army with the signing of the new trade training contract.

The five-year contract is the largest training contract within the Australian Army Training Command and is the culmination point of an exhaustive twelve-month tender, evaluation and selection process. SMA was able to successfully demonstrate to the Commonwealth that they could not only deliver quality trade training at ALTC but also do so in a cost-effective manner.

SMA is one of Australia's largest suppliers of integrated logistic support services to Defence. The company currently delivers technical training for the Royal Australian Navy at HMAS Cerberus, Victoria. The new contract with the Australian Army will be the company's largest trade training contract.

SMA staff will be integrated into one of ALTC's training divisions, Materiel Support Division which delivers Mechanical, Engineering, Electrical, Electronic, Construction, Ammunition and Armament trade training to defence personnel. It is responsible for Initial Trade Training, Initial Employ-



Signing of the contract

ment Training, Advanced Technical Training and Specialist Equipment Training.

In more recent times, Materiel Support Division has also been responsible for the initial trade training of Royal Australian Airforce Ground Support Equipment Fitters and Royal Australian Navy Calibration Technicians. At any one time there are in excess of 600 defence personnel undergoing trade training either in the Division at ALTC or at one of its On the Job Training locations in Sydney, Townsville, Brisbane and Darwin.

SMA will be responsible for assisting ALTC in providing training for 17 of the 40 courses currently conducted by Materiel Support Division.

ALTC has had a long history of using contractors to assist with the delivery of quality training for defence personnel. SMA is the third company to be contracted to provide trade training at ALTC and will take over from the current contractor, RMIT University in January 2004. RMIT University will continue to support ALTC in the provision of medical training for Army and Air Force Medical Assistants.

Proud to be associated with the Royal Australian Army



## MARSHALL'S DIESEL SERVICE

Service & Repairs to All Types of Diesels.

**FUEL INJECTION - REPAIRS & SERVICING**

We service everything from Landrovers and Macs to Unimogs & Earthmoving Equipment

"Give Your Diesel the Care It Deserves"

Phone (07) 4728 4300 Fax (07) 4728 4399 Mobile 0403 576 989  
5 Keane Street, Currarajong Qld 4812

## ADVANCE FENCING

MAJOR DEFENCE CONTRACTS UNDERTAKEN

- COMMERCIAL • INDUSTRIAL
- DOMESTIC

FENCING & RETAINING WALLS

Phone PAUL CAMERON

5497 0017 • 0419 520 120

Bill O'Neill  
 28 Bass St,  
 Barrack Hgts.  
 N.S.W. 2528

The Editor,  
 RAEME Craftsman.

Dear Sir,

as always my thanks for a wonderful publication that certainly must be the envy of quite a few other Corps.

Last ANZAC Day proved to be a rather special one for me for after the march I adjourned to the Sydney venue (The Crown) for what I thought would be the usual old tales of how things were but instead much to my absolute delight I was adopted by many "Crafties" and N.C.O.'s from predominately the 17th Construction Sqn. The hospitality extended by both these men and their sweethearts only went on to prove to me that the Corps is is alive and some thing as always that I am proud to be a part of.

The real purpose of this letter is to add to what was written by "Tiny" Hepburn another old Corps man from the days when both the Corps and I were young.

Although I do not recall "Tiny" I do remember such men as the "Beast of Broady". our R.S.M. of that time. But it would be remiss of me not to recall all of the men from those days who went on to be a part of the legend of the Corps. 3 Base Workshop was my first posting at the close of 1951 and my first taste of Melbourne. There was the Queenslanders who perpetually lived in their great coats. Terry Leong, Dust Miller and Johnny Boar just to name a few. Johnny could play the meanest hand of cards that the army ever seen dealt. Dusty drove any thing that had wheels on it and Terry went on to bigger and better things in the Corps. There was Keneth, Michael, Xavier, "Snow" Robson who could lead the saints astray. Stan Chidly a fitter who could turn up a chariot for Ben Hur if called upon. Then there was Cpl. John ("Lumpy") Emond, Sammy Gibbs and one of the best of all Cpl. Bruce Snedden, "Snow" to his mates. He was a man who could ride any thing on two wheels or for that matter on four legs.

And if all of that was not enough to give the "Beast" grey hair then there was the usual influx of army apprentices who fresh from the discipline of Balcome were chaffing at the bit for a bit of freedom. Each of these young blokes had invested their back pay in a motor bike and their exploits around Broadmeadows were legendary.

As Tiny tells it the old wartime huts were a sight to see let alone live in and in the middle of a Victorian winter it was enough to freeze the grommets off of a Craftsman.

I recall that the regulation was that to get back to the lines during working hours.

required a "chit" from the orderly room. The only time that this created a bit of a problem was when one of more diligent of the "Crafties" had perloined a 9 gallon keg and it was secreted in a wardrobe in hut such and such. For two days, there was a constant stream of workshop personnel requiring permission to return to the lines for many and varied reasons.

Whilst on the subject of drinking the nearest venue outside of the camp precincts was the Red Roof Hotel down on Sydney road and the ambience of this establishment left a lot to be desired. As then and may be it still might, it fronted onto the Hume Highway and there was a constant stream of traffic past the front door. As I recall one night halfway through a pretty heavy session at the back bar a good mate of mine wished all a good night and said he was off home if he was able to stand up. Five minutes later said "Craftie" comes in and plonks back onto a bar stool and orders a rum. The crowd was pressed around that bar and "Dalray" (as he was known), one bloke remarked that they thought he was going home. "Dalray" rejoined "I was but I got run over". It was then that we noticed he was bleeding from several wounds of varying degrees. "Dalray" had staggered out of the Red Roof onto the highway and was "skunked" by a passing truck. Needless to say that he consumed several more rums before he condescended to be carted off back to camp in search of our ever handy R.A.P. Sergeant Doctor Death.

Yes the Corps was young in those days, there was the Queens visit and bush fires to be fought and Military Tattos to perform but I am sure now that were I once again that young green "Craftie" there would still be to days version of all of those blokes who went on to make the Corps what it is.

I guess that I could go on and on about those times and bore the readers stiff. so for now I shall give it away with one wish Mr. Editor, How about an "Old Sweats" segment occasionally just to recall the unofficial history of the Corps.

Sincerely Bill O'Neill

**POINT LOOKOUT PLUMBING**

• DRAINAGE • ROOFING & GUTTERING • HOT WATER • GAS FITTING

★ Commercial ★ Industrial ★ Domestic

**DEFENCE PROJECTS UNDERTAKEN**

PH: GLEN KELLY

PH: 0409 476 402 AH: 3409 8407

**PK PAVING & BUILDING SERVICES**

DOMESTIC & COMMERCIAL PAVING SPECIALISTS & CONSULTANTS

— Servicing Darwin since 1978 —

**All Work GUARANTEED • FREE QUOTES**

• Also Specialising in Soft Fall Rubber Crumb

Paul Kelly: 0417 883 375 Wayne Finn: 0407 612 159

82 Lakeside Drive, Alawa, Darwin, NT 0810 Fax: 8948 2588

## Brigadier R.S.P. Amos, RFD, ED 1927 to 2003

Brigadier Roger Stuart Phillip Amos, RFD, ED, passed away on 18 August 2003 after a long illness. Known to many as 'The Brig' or 'Uncle Phil', he was a stalwart of the Corps for many years. He was the well-respected Patron of the RAEME Association in New South Wales, and only relinquished his role earlier this year when illness prevented his continuation. Phil Amos was one of only two RAEME officers to reach the rank of Brigadier while serving part-time.

He studied electrical engineering at university, and enlisted in the Citizen Military Forces (CMF) on 29 July 1948. Initially joining Sydney University Regiment, where he became a Lance



Corporal, he transferred to 103 Infantry Workshop on 15 April 1950, where his long career with RAEME began. Not long after his transfer to the Corps he was promoted Corporal.

Although having the qualifications to become an officer, the RAEME 2nd Division policy at the time was for all new officers without prior

service to spend time in the ranks before sitting for the first appointment examinations. Soldiering on in the ranks he was promoted Sergeant in January 1951, and commissioned as a probationary Lieutenant on 10 April 1951. He was posted to 102 Infantry Workshop and his rank was confirmed in March 1952.

Service in the workshop was followed by a posting to 17 Light Anti-Aircraft Regiment Light Aid Detachment (Technical Support Troop for our younger readers), where he served for three years. During that time he was promoted to Captain.

As was often the case in the CMF, he was posted back to his original RAEME unit, 103 Infantry Workshop at Leichhardt, in February 1957 and

appointed the Officer Commanding. Later that year he was promoted temporary Major, and this rank was made substantive in June 1958.

He transferred to the Reserve of Officers (Inactive List) in February 1961 for two and a half years, returning to the Active List in June 1963 as the DADEME (Deputy Assistant Director of Electrical and Mechanical Engineering).

In October 1964 he was promoted Lieutenant Colonel and was posted to Headquarters 1 CRAEME Communications Zone. Changes in unit names and roles followed, but he remained a RAEME Lieutenant Colonel in 2nd Division until November 1969, when he was detached to Headquarters Communications Zone.

By this time in civilian life he was a Director of Email Limited, the large electrical switchgear and whitegoods manufacturer located in Waterloo in Sydney. The author of this article had then completed one year of his apprenticeship with Email, and over the Christmas period was detached to the administrative section for a few weeks. Waiting to be called forward for enlistment into the CMF – in those days there was a waiting list – it was with trepidation that I entered the hallowed executive area one day, only to be met by none other than Phil Amos. He immediately knew who I was and that I wanted to join RAEME, and made me feel like a member of the Corps already.

In January 1972 he was appointed the AA & QMG of Headquarters 2nd Division, and on 1 May was promoted Colonel and appointed Deputy Commander Eastern Command Training Group. At the end of 1973 he was posted to Headquarters Communications Zone (HQ COMMZ).

Promoted Brigadier twelve months later, he was appointed the Commander Communications Zone. Subsequently the unit was designated Headquarters Field Force Command Logistic Planning Staff.

It was during this period he was appointed as Honorary ADC to Her Majesty Queen Elizabeth II for a period of two years beginning May 1977.

Transferred to the Reserve CMF at the end of October 1982, he retired on 17 July 1984 after 36 years service, 34 of which were in RAEME.



Even in retirement he retained his interest in the Corps and was the RAEME Colonel Commandant 2nd Military District from August 1983 to August 1989. In this role he attended many activities undertaken by units of the Corps, both regular and reserve. Attending most of the major reserve exercises, he never failed to speak to virtually every RAEME soldier, regardless of rank, that he met.

As the RAEME Representative Colonel Commandant from July 1986 until August 1989, he did much to ensure that the Corps history was recorded and was instrumental in the publication of "The Craftsmen of the Australian Army".

During his retirement he was also the Honorary Colonel of the University of New South Wales Regiment from October 1985 to October 1991.

As the Patron of the RAEME Association of New South Wales he always provided valuable advice and guidance to the President and the Committee, and always had a word for individual members. His "pork pie hat" will be sadly missed on Anzac Day marches in Sydney.

Phillip Amos was cremated privately. He is survived by his widow, Kath, and two adult children.

The author wishes to acknowledge the assistance of Major Stefan Hreszczuk and Mr Andy Moffat in the preparation of this article.

*Prepared by Major Paul Handel, Army History Unit.*

**53489 Peter John Gallagher**

28 Nov 1933 – 18 Sept 2003

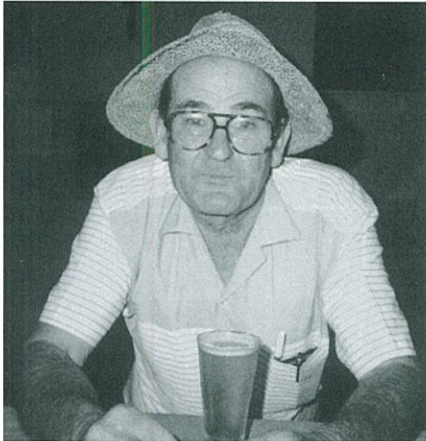

Peter Gallagher was well known throughout the corps and was never one to leave you in doubt about what he thought.

A real "backroom boy", he supported the tradesmen of the corps in many ways. Who could forget the white table cloths and candelabra on FS tables during Paratus Cup when RPS Resup was on. Get the "bits" have a feed and get back to it.

Peter was married to Betty who pre-deceased him and they had six children.

Peter died peacefully at his son-in-law's home in Wodonga after many years fighting off cancer.

He will be "blimmin-well" missed.

**Place of Birth:** Fremantle, WA

**Occupation:** Storeman

**Service Details**

Army No: 53489

Rank: Warrant Officer Class 1

Corps: Royal Australian Electrical & Mechanical Engineers

Service: National Service – 3 Jan 1952 to 9 Apr 1952; Citizen Military Forces – 10 Apr 1952 to 2 Jan 1957; Australian Regular Army 13 Aug 1958 to 12 Aug 1979.

**Units Served**

- 3 Jan 1952 – 17th National Service Training Battalion
- 10 Apr 1952 – 3rd Field Regiment
- 10 Sept 1958 – 1st Recruit Training Battalion
- 16 Dec 1958 – RAEME Training Centre
- 3 Mar 1959 – 2nd Base Workshops
- 27 Jul 1960 – 1st Company RAASC Workshops
- 25 Oct 1961 – Central Command Workshops
- 20 May 1963 – 107th Infantry Workshops
- 7 Dec 1965 – 107th Field Workshops
- 13 Mar 1966 – 1st Armoured Regiment Light Aid Detachment
- 24 Oct 1967 – 1st Independent Armoured Squadron Workshops
- 2 Feb 1968 – 1st Armoured Squadron Workshops
- 9 Dec 1968 – Western Command Workshops
- 11 Dec 1969 – RAEME Training Centre
- 24 Mar 1971 – 4th Base Workshops
- 4 Feb 1974 – Headquarters 1st Armoured Regiment
- 23 May 1977 – 1st Armoured Regiment
- 24 Jan 1978 – RAEME Training Centre

**Promotions**

- Corporal – 25 Oct 1961
- Temporary Sergeant – 21 May 1963
- Sergeant – 1 Jul 1963

Warrant Officer Class 2 – 13 Apr 1966  
Warrant Officer Class 1 – 18 Nov 1976

**Overseas Service**

South Vietnam from 29 Dec 1967 to 8 Oct 1968 with 1st Independent Armoured Squadron Workshops (redesignated as 1st Armoured Squadron Workshops on 2 Feb 1968).

**Kenneth Brian Fitzgerald**

Ken Fitzgerald (Fitzy) passed away on the 7th Aug 2003. He was one of the members of Tech Squadron 1st Joint Support Unit workshop team who provide endless maintenance support to 1 JSU and other dependent unit's equipment. Ken had been employed by the DOD for almost 20 years. Ken supervised and controlled the servicing area for vehicles within the 1 JSU workshop compound. Throughout this period he provided trade assistance and guidance to both military and civilian personnel to ensure the equipment was maintained to a high standard.

Ken could be relied upon at all times and would assist in any area if he could. Ken will be sadly missed not only by the current members of 1 JSU, but all the people who were fortunate to have been in contact with him over the number of years.

Ken had a great passion for football and would remind you of which team was the best. He was an avid supporter of the Bob Pitman Club and Ken's sense of humour provided memorable conversations.

Our deepest sympathies go to his family, his partner Daphne and son Brad.

**Condolences as published in Melbourne Sun-Herald**

<p><b>BREEN.</b> — Stanley W. VX133887 216 Aust. Lad (AIF) AEME The President, Committee and Members of Caulfield RSL regret the passing of their esteemed Member. Lest We Forget</p>	<p><b>HALL.</b> — William F. (Bill), May 27, 2003. The President and Members of the R.A.E.M.E. Assoc. Vic. Inc., deeply mourn the passing of their esteemed colleague. Deepest sympathy to Joyce and family. <b>LEST WE FORGET</b></p>	<p><b>TAYLOR.</b> — Eric Harry, Reg. No. 5121929 R.E.M.E. The President, Committee and Members of the Chelsea RSL Sub Branch regrets the passing of their colleague, and respectfully offers sympathy to the family. Lest We Forget</p>	
<p><b>HALL.</b> — William F. Passed away Thur. May 27, 2003. After a very difficult illness, he is now at rest. Bill was the President of Stawell RSL from 1994 - 2003 and an RSL State Councillor from 1997 - 2003. A dedicated and hard working gentleman who will be sadly missed. Sincere condolences to Mrs Joyce Hall and family on their very sad loss. From the State President, State Executive, Members and Staff of the Victorian Branch of the RSL. <b>LEST WE FORGET</b> MAJ GEN D McLACHLAN AO State President BRIG J P A DEIGHTON AM MC State Secretary</p>	<p><b>PEARSON.</b> — Bill, VX59295 2/2 Aust. Base W/Shops. The President, Committee and members of the Pascoe Vale RSL Sub Branch regret the passing of their esteemed member. Lest We Forget</p>	<p><b>SMITH.</b> — Albert William. RAEME 3772179 The Committee and Members of the Sunbury RSL Sub-Branch regret the passing of our esteemed Member. Lest We Forget</p>	
<p><b>ROBERTS.</b> — John William, Reg. No. VX79206 Unit, 2/3 Inf. Troop W/Shop. The President, Committee and Members of the Ringwood R. &amp; S. L. Sub Branch Inc. mourn the passing of their late comrade. <b>LEST WE FORGET</b></p>	<p><b>STEWART.</b> — Donald VX23928 Unit No. 2/78 L.A.D. The President and Members of the East Malvern RSL Sub-Branch Inc. regret the passing of their esteemed Member on Mar. 25. Deepest sympathy to the family. Lest we forget</p>	<p><b>WALSH.</b> — Les. 1st Indep. Armoured W/shops Ivanhoe RSL mourn the loss of a well respected member. Deepest sympathy to Gwenda and family. <b>LEST WE FORGET</b></p>	
<p><b>WHITE.</b> — William Patrick. VX39733 2/142 Aust. Workshop. The President and members of the Balwyn RSL regret the passing of a comrade and extend their deepest sympathy to the family. <b>LEST WE FORGET</b></p>			

# acknowledgements

## Tribute to 42809 CFN D. G. Borlace

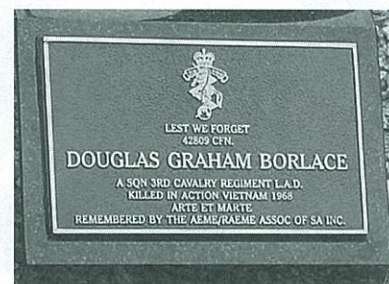

Association President Mike Culley, Army Reserve Chaplain Catie Inches-Ogden and Bob Killoran

The AEME/RAEME Association of SA Inc paid tribute to 42809 Craftsman D.G. Borlace on the Sunday the 3rd of August 2003 at 1400 hrs.

Born 10 July 1944, fostered to the Peacock/Little family at age nine months, Doug grew up in Anzac Ridge Road, Bridgewater. After leaving school enlisted in the Army on 29 Dec 1961 entering IRTB 10 Jan 1962, after which he was allocated to RAAC 12 April 1962 as a trainee driver/signaler and posted to 1st Armoured Regiment on the 20th August 1962 as a Centurion Tank crew man. He must have got interested in the mechanical monsters because he Corps transferred to RAEME to train as an adult tradesman in the 3/65 Vehicle Mechanics course from 29/9/65 to 13/9/66.

Posted back to 1st Armoured Regiment LAD as a VM 14/9/66 posted to A SQN

3rd Cavalry Regiment LAD at his request before it was sent to Vietnam. He arrived in Vietnam on 11 June 1968.

He celebrated his 24th birthday on the 10th of July 1968. Unfortunately on the 15th of July 1968, whilst traveling on a M113 APC 30B, driven by Tpr Gerard O'Neill of Perth, with a troop from A SQN during a reconnaissance in force, (Operation Albany?) he was killed by an enemy mine explosion in the scrub of the Long Green area of Phuoc Tuy Province. He had been in country just over a month. Doug was sitting on the rear hatch of the carrier, the vehicle driver believes the mine was possibly tied up in the trees, the blast raking across the top of the vehicle killing Doug and wounding the crew commander/machine gunner, after the blast the vehicles were raked by auto weapons fire, confirming that it was probably a tree mounted command detonated mine.

When we realized the official headstone made no mention that Doug was killed in action, we sought to therefore distinguish his grave from graves of other old soldiers, who returned and lived normal lives for many years, we thought, in the 'Spirit of Lest We Forget', that we would seek permission to fit a supplementary plaque to emphasise this point and remember Doug's sacrifice. For this to happen, we sought permission from and we must thank Doug's family, Mrs. Margaret Little, Ms Lyn Little, also Mr. Keith Thorogood from The Adelaide Office of Australian War Graves and Ms Gaye Abel from the Adelaide Hills Council.

Doug would be entitled to the Australian Active Service Medal 1945-1975, Australian Vietnam Medal and the Vietnamese Campaign Medal from the



Kevin Little (Doug's Family), David Turner (Assoc Sec), Mike Culley (Assoc Pres), Margaret Little (Doug's Family)

former South Vietnamese Government and the family are seeking to acquire his medals which hopefully can be achieved with due respect for Doug's sacrifice. Lest we forget. 42809 Craftsman Douglas Graham Borlace 10/7/1944-15/7/1968.



Bugler - GRES CPL Andrew Barnett

# Farewell WO1 Michael (Shakey) Shanahan

By WO2 P.J. Yates

**O**n the 16 Sept 03, one of the Patriarchs of the Recovery Trade bid farewell from the Australian Army after 33 years of service. Shakey's choice to retire was bought forward by a year or so when he was offered Management Induced Redundancy (MIR) earlier this year, which he happily accepted.

Shakey was born on the 22 May 1950 and was called up for National Service in July 1970 in which he saw service in Vietnam. After returning from his tour of duty Shakey discharged in January 1972. As he says, he could not settle down after his discharge so he re-enlisted to the ARA in October 1972 and was posted to 2 Base Wksp as a Storeman Tech.

After two years, Shakey was posted to 2 Cav Regt and it was during this time he made the best decision of his military career and decided to trade transfer to Recovery in April 1977. After completing his Basic Recovery Mechanic's course, Shakey was posted to 1st Armd Regt in August 1977 and was promoted to CPL in November 1977. Shakey had two further postings as a CPL and they were 8/12 Mdm Regt and 22 Constr Sqn before being posted on promotion to SGT to the School of Armour in January 1983. This was followed in January 1985 with a posting back to 2 Cav Regt then rebounding back to the School of Armour in March 1987.

In June 1988 Shakey was posted again to 1st Armd Regt before being promoted to WO2 in August 1988, followed by a posting to 101 Fld Wksp in September 1990. Promotion to WO1 came in July 1992 when Shakey was posted to RAEME Training Centre as the OIC Recovery Platoon, followed by postings to DEME-A in October 1996 then MEA in December 1997. Shakey was again posted as the OIC Recovery Platoon in January 2000 when he was posted to ALTC before he was posted on his final posting to HQ LSF in January 2003.

Shakey lists his career highlights as Nasho's, becoming a Reccy Mech, Tp Leader Recov Tp 1 AR, MEA and his postings to RTC/ALTC.

No doubt for someone that has a long and distinguished career there would be many stories to be told about Shakey, one that comes to mind was a story of when he was in Vietnam. Shakey was the

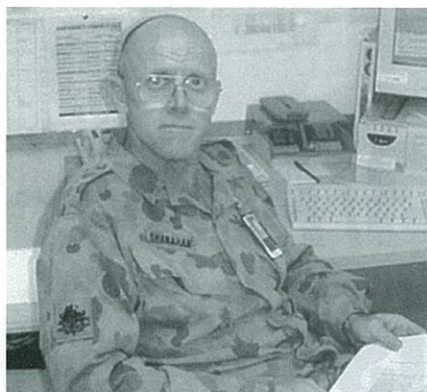

WO1 Michael Shanahan

driver for a group of Ammo Tech's, anyway they had buried a lot of ordnance on a beach and set it to blow up. The fuse was lit and they all moved out of the danger area. After a period of time nothing happened and waiting the further stand off time they moved back to the pile of ammo. One of the Ammo Tech's moved some of the sand only to discover a lit fuse. As Shakey said they all turned

to run, but realising the hopelessness of running one of the Ammo Tech's grabbed the offending fuse and pulled it out of the ammo pile, to the great relief to them all.

A couple of the notable moments of Shakey's career were his involvement in the early stages of the new Heavy Recovery Vehicle and more importantly the pay case which saw Recovery Mechanics go from pay group 3 to pay group 4, so that all reccy mech's are in debt to Shakey for his tireless work to secure this rise.

Finally, Mick and his wife Julia and his daughters have moved and settled on the north coast of NSW at Taree where he will spend his time sailing, playing golf, following the Parramatta Eel's and looking out for those old war birds as they fly over. Last thing Shakey, on behalf of all the Recovery Mechanics we express our best wishes to you and Julia on your retirement and keep our secret fishing spot going at Harrington.

## Farewell CFN Barry Naulty

By 2LT Williams, AE PL COMD

**T**uesday 27th May 2003 saw the DHOC Lt Col Creagh and Corps RSM, WO1 D.Packer, visit 107 Fd Wksp 9 CSSB, to raise some issues and give updates on current RAEME activities. Quite timely, it seemed, was their arrival as that night was also the official farewell to CFN Barry Naulty.

After 22 years of service with the army reserve, more importantly 9CSSB and its various other predecessors, CFN Naulty reached the age of compulsory retirement. During his time with 9CSSB CFN Naulty demonstrated a high level of competency and technical proficiency and to acknowledge these efforts received the soldiers medallion in 1997 for exemplary service.

CFN Naulty is a well-respected member of 107 Fd Wksp and he will be greatly missed. After successfully receiving 2 age extensions, time ran out for this craftsman and CFN Naulty needed to hang up his RAEME spanner.

A character as good as his word "Don't worry about that!" he was almost lost for words and somewhat humbled when presented with his workshop momento comprising of a very large wood-mounted chromed bolt and spring washer assembly.

All members of 107 Fd Wksp will miss CFN Naulty and his happy demeanour.

CFN Naulty, we wish you well in the future and sincerely thank you for your enormous contribution over the years.



CFN Naulty being presented with his 9CSSB farewell momento from CO LtCol Gillespe

# article

## M113 AS3/AS4 – The Upgrade is finally upon us

By Peter Dodgson,  
Technical Officer M113 Upgrade

### Introduction

For those old RAEME soldiers among us, cast your mind back to 1983 when there was to be an upgrade of the M113 Family of Vehicles (FOV). During the next 19 years, there have been many projects for the upgrade of the M113 FOV, such as Project Waler, but with no end result to the vehicle. There is now a result.

As of July 2002 a contract was signed with Tenix Defence Pty Ltd to upgrade the M113 FOV. The first Demonstration Vehicles (DV) were trialed in Northern Australia during the period September to November 2003.

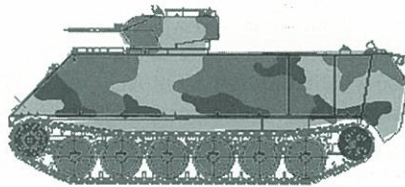

### The Facts

The Army is upgrading 350 vehicles of the existing fleet. Production is scheduled to begin at Bandiana in 2006. Prior to the production, two DVs will be produced at Tenix's Adelaide facility to prove the product. This will be followed by 14 Initial Production Vehicles (IPV), which will undergo significant testing and trials. The last of these vehicles are planned to be introduced into service by late 2010.

### Types of Vehicles

The 350 vehicles will be of an AS3 and AS4 standard. The main difference between these two designations is that the AS4 will be a stretched vehicle, containing an extra roadwheel station and a RGVM of up to 18.0 tonnes. The AS3 will not be stretched and have a RGVM up to 15.0 tonnes. Both variations will have the same powerpack and driveline and there will be only minor differences between the vehicles and variants.

The scope of the project provides the following variants:

- M113AS4 APC – Qty 171 (Personnel Carrier)
- M113AS4 AF – Qty 38 (Fitters)
- M125AS3 AM – Qty 21 (Mortar)
- M577AS3 ACV – Qty 43

### NOW! LUBRICATION ANSWERS AT YOUR FINGERTIPS!

If you need oils & greases to meet DEF (Aust) / JSD /NATO/US MIL or other Service specifications, then you need only to call:

Castrol Performance Lubricant  
**1800 802 043**

We stock BRAY and CASTROL AVIATION products and are happy to assist you in locating those hard-to-find speciality products.

Use us as your personal lubricant consultants.

Ring us now on  
**1800 802 043** for our special brand of new fashioned service!

## WELDING & ELECTRICAL SERVICES

Cnr Lavarack Ave & Harvey St Nth  
Eagle Farm, Qld 4007

CONTRACTOR TO THE ARMY

Welder and Generator Repairs  
Generator Sets • Spare Parts  
Motor Rewinds  
and Electric Motor Parts

Telephone  
**(07) 3268 3866**

Fax  
**(07) 3268 7822**

Email: [weldelec@bigpond.com.au](mailto:weldelec@bigpond.com.au)

## IT Environmental

- EIS, Planning & Ecological
- Air, Noise, Dust & Water Monitoring
- Due Diligence Audits
- Contaminated Site Assessment & Remediation
- Contaminated Land Auditing
- EMS & Facility Auditing

**We're the environmental  
company that does more than tell  
you what the problem is.**



**We clean it up.**

Northern Territory: (07) 3252 5711  
Western Australia: (08) 9481 4333  
Web site: [www.itenviro.com.au](http://www.itenviro.com.au)

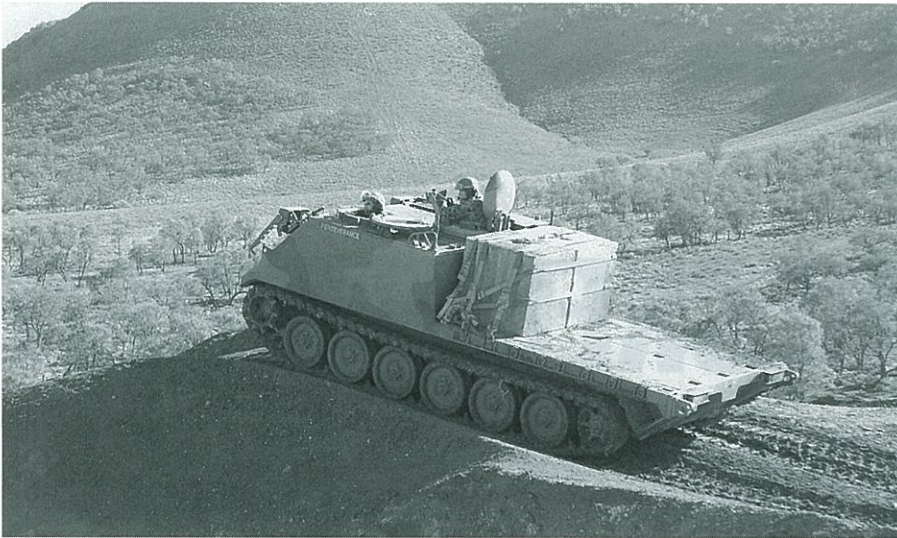

(Command Post)

- M577AS3 AA – Qty 15 (Ambulance)
- M806AS3 ARVL – Qty 12 (Recovery)
- M113AS4 ALV – Qty 50 (Replacement TLC)

The vehicles basically look the same as the original, with the exception of the ALV (Armoured Logistic Vehicle) which is the replacement for the TLC. The picture below explains the concept:

### The Upgrade

The vehicles will be upgraded with the following hardware:

- **Powerpack**
  - MTU 199 Engine producing 260 kW
  - ZF automatic transmission with 6 forward and 2 reverse gears
  - A true pivot turn is incorporated
  - Integral hydraulic steering system
- **Braking**
  - External to the power pack disc brakes
  - Foot pedal (laterals are replaced by a steering yoke)
  - 18 tonne braking system, hydraulic handbrake for AS4.
  - 15 tonne braking system, manual handbrake for AS3.
- **Suspension**

- A2 suspension.
- New torsion bars
- 4 shock absorbers per side
- **Driveline**
  - Upgraded Final Drives
  - One Propshaft and one Coupling transfer drive.
- **Track**
  - The DVs and IPVs will be fitted with United Defense LP T150F Track System

- The AS4 utilises 145 track links
- **Fuel system**
  - All vehicles will have two external fuel tanks except the ALV and ARVL
  - An electric fuel pump
- **Turret**
  - Tenix are designing a new turret for the AS4 APC
  - Hand held duplex for traverse and elevation control of turret
  - Commander's Sight
  - 50 Cal QCB
- **Armour**
  - The fleet will be fitted for applique armour and spall curtains
  - The fleet will incorporate enhanced mine protection components.
- **Electrical**
  - 4 Batteries in two sets.
  - Starting batteries / Turret Batteries
  - Drivers Night Viewer (DNV)

### Conclusion

The APC Upgrade is still in its infancy, but will deliver a modern, upgraded vehicle in the near future. For further information feel free to access the following directory: <http://lsdweb.lsd.defence.gov.au/land106.htm>





**VOLVO**

**MACK TRUCKS AUSTRALIA PTY LTD VOLVO**

NEW & USED TRUCKS – TRUCK & TRAILER PARTS, SERVICE & REPAIRS – ALL MAKES ALL MODELS

**8984 3714**  
**Fax: 8947 0182**

**24 Hours Parts & Service**  
1890 Berrimah Road, Berrimah

**OBE'S CONCRETE SERVICE**

**DOMESTIC, COMMERCIAL & INDUSTRIAL**

STENCIL DRIVEWAYS, FOOTPATHS, HOUSE SLABS & PATIOS

**Contact Chris**  
**Mobile: 0417 818 007 – Phone/Fax: 8988 5812**

**MULLINS & WATSON'S ENTERPRISE AND HIRE PTY LTD**

Steel fabrication and welding • Site erection • Mild steel handrails  
Balustrades are our specialty

DEFENCE PROJECTS UNDERTAKEN  
*Enquiries to Andy Mullins, Graham Watson*

**Phone: 3279 1252 Fax: 3279 1262 Mob: 0407 027 497**



**Petroleum Engineering & Construction Co Pty Ltd**

**Supply Installation & Maintenance of**

- Pumps Tanks & Pipe Work to Service Stations, Industrial Sites & Marinas
- Drawings to Local Authority Requirements
- Decontamination to Govt. Requirements

Sales & Service for Fuel Pumping & Data Capture Systems

**3888 7622 ALL HOURS**  
**Mobile: 0414 984 007**  
**Fax: 3888 7633**

142-144 Lakewood Drv, Burpengary  
Email: [peteng@hotmail.net.au](mailto:peteng@hotmail.net.au)  
PICA Member

## M816 WRECKER REBORN

### The Reg Wildermuth Bar

By Mr Shane (Sparra) Layt

It's a cliché, but the week that led up to me writing this article has been like a walk down memory lane, abounding with fond memories of great friends, professional colleagues and many very satisfying, but hard hours work in the once RAEME Corps Sergeants Mess at the ALTC (RTC) in Bandiana. I have been out of the service for almost five years now, but am currently working as a Professional Service Provider (PSP) in Mobility SPO at Victoria Barracks Melbourne on a number of projects. I was fortunate enough to be able to attend the Southern Region RAEME Corps Dinner on Fri 5 Jul 03, and I assure you that the Esprit de corps is very much alive and well and it is very

satisfying to see the return of a Head-of-Corps in BRIG Dave McGahey CSC.

As a prelude to writing this article, I'd sent an email to the Western Region RAEME Association in regards to an editorial I used to co-write and illustrate over there (The Horses Mouth). This correspondence reached the RAEME Craftsman's editor's desk and as a result I was asked to write an editorial for the *RAEME Craftsman* magazine about the marquetry mural I did for the Reg Wildermuth Bar at the RAEME Corps Sergeants Mess. For those of you who had visited The Corps Mess from late 1990, when I finished building the bar, I am referring to the mural of the M816 Wrecker that was the centre feature for the bar (pictured below).

The Corps Mess committee had commissioned a private agency to draw up and quote for building of a new bar in the rear annex of the Corps Mess prior to my taking up the position as improvements member. I was a chippy (Cabinetmaker) prior to joining the Army and had already helped to build numerous clubs and bars in my previous postings, so I volunteered as the Improvements Member of the mess shortly after being promoted to Sergeant in April 1990. The original contractor's design for the bar looked like a couple of old barn doors, so I drew up some new plans, costed the materials and presented the new design to the committee at one third of the original quoted cost. The new plans and prices were quickly approved by the committee, but I did not disclose my ideas for the bar centrepiece, as this was to remain a secret until the bar was actually officially opened.

The bar itself took nearly three months of weekend work to build, and the marquetry of the M816 was shaping up in my loungeroom for almost the same period (much to my wife's dismay). The marquetry itself took 150 hours to complete. WO1 Geoff Lowe was the RSM at the time of this construction (Geoff was appointed as the first RAEME Corps RSM) and it was decided by Geoff and the members of the Committee that the name of the bar would be the individual who was largely responsible for the new rear annex of the mess, and that was Reg Wildermuth (Laughing Boy). Reg was a Wrecky Mech of some long standing, so the choice for the design of the mural (at least to me) seemed obvious. The mural was to be the last thing to go onto the bar, and even then it was only

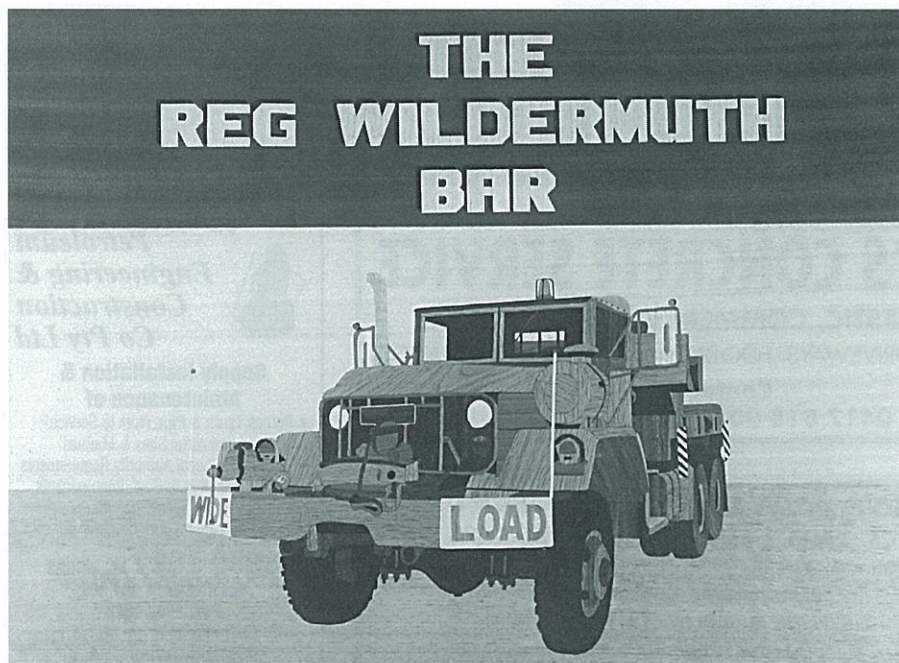

The Marquetry Centrepiece of the Reg Wildermuth Bar

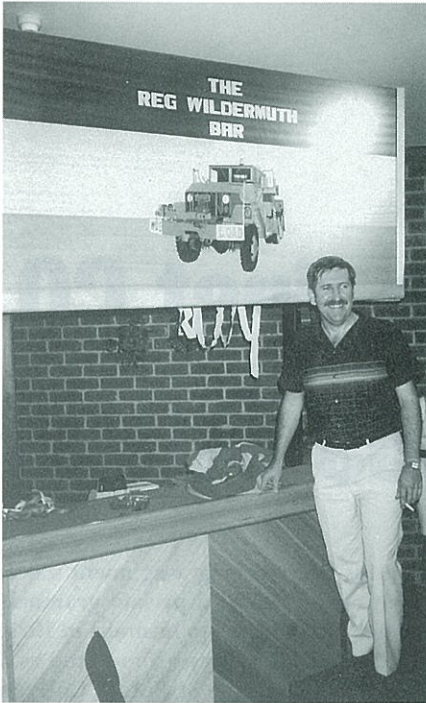

Shane (Sparra) Layt at the front of the bar on opening night



The completed Reg Wildermuth Bar

revealed to Geoff Lowe prior to opening day, because he came to my place and fed me coffee so I could finish it for the Christmas function.

For those who are still unsure, marquetry is the process of carving and then inlaying veneers onto a solid timber backing to make a pattern or picture. Many quality period pieces of furniture used timber veneers, ivory, precious stones and mother of pearl to form intricate designs.

The design I'd chosen of the M816 Wrecker was very difficult, because the selection of the veneers not only had to have many shades and grains to "paint the picture", but it required the detailed selection of the correct timber colour and grain pattern to portray the actual shape of the equipment. A case in

example, which is easy to see in the picture of the mural, is the grain selection for the bonnet. I had to search through over 30 sheets of veneer at the suppliers just to get the grain shape I wanted. The mural was also very large, measuring 1800mm x 900mm (6x3 sheet for us oldies).

There are 10 different timbers used to get the colours and textures required for the mural, including Silky Ash, Queensland Maple, Black Butt and Macassa Ebony to name a few. This also includes the three veneers used as the background, which are symbolic shades of the three Corps colours. One thing that most people fail to recognise is that the name of the bar is also done in inlaid veneers. Each piece of veneer was individually hand carved to fit into the

overall design, joined together with special veneer paper tape and then glued into position. Although I didn't get any photos of the M816 in progress, I did get some of the 50th RAEME Jubilee Marquetry I did that was later presented to Corps Mess and now (I believe) hangs in the Area Mess at Bandiana. This mural, although not as large, was finer in detail and took almost 90 hours to complete.

The bar was officially Opened by MAJ-GEN John Kingston just prior to the 1991 RAEME Corps Dinner, and a plaque was affixed to the front of the bar to celebrate that occasion.

During my service with RAEME, I helped build numerous bars and clubs that were enjoyed by many of the members of the Corps. These included renovations and improvements to Perth Wksp Bar, Moorebank Area Sergeants Mess, The Bluebell Tavern at 2 Base Wksps and the RAEME Corps Sergeants Mess. No one does all this on their own, and I had many willing workers (although usually the same willing workers) who helped out at numerous weekend working bees. Leaving out the many scrounging trips, the bartering and graft and corruption bits, in many ways we got most of these built with skill and by fighting (*Arte-et-marte*). Most of these bars and clubs have now been laid to rest, victims of the inevitable change that we live with today, but their memory and the times that we all had together in them will certainly remain with me for the rest of my life.



Progress work on the 50th Jubilee Badge

# article

## Colonel F B Oldfield, the first CO of the Army Apprentices School

**M**rs G Chapman the third daughter of the first commanding officer of the Army Apprentices School (AAS) has recently presented a duplicate set of his medals and military insignia to the Army Museum Bandiana. The medals are beautifully mounted and are displayed next to the honour board of all CO's of the AAS.

Frederick Bernam Oldfield was a soldier with an interesting career. He was born in Melbourne on the 19th September 1897 and enlisted in the Australian Imperial Forces on the 13th of October 1916, at 19 years of age. His civilian occupation was listed as "School teacher" and his enlistment form shows he had four years service with the school cadets. He served with a number of Artillery units as a Gunner and Lance Bombardier. He served in France where he was listed as wounded in action - gas poisoning. After six weeks recovering in Southampton hospital he returned to the front in France. His total service with the AIF was two years, 322 days of which two years, 112 days were shown as service abroad. He took his discharge in London



COL Oldfield

on the 30th of August 1919, where he received the sum of sixteen pounds deferred pay. He was awarded the British War Medal and the Victory medal.

After his discharge he remained in England where he gained degrees in Science and Education. After his graduation

his first teaching assignment was at Trenton on Sea at a private grammar school. He returned to Australia in 1925, was married and spent some time as a resident master at St Peters College Adelaide before becoming resident master at Ballarat Grammar. He later taught at Scott's College Melbourne. He enlisted in the reserve forces and then moved to Sydney in the late thirties where he was employed as sub editor for the ABC. During this period he served with the Citizen Military Forces.

He re-enlisted in the AIF on 6th January '41 with the rank of Lt and was on his way by the end of January to serve with 1 Advanced Ordnance Workshop in the Middle East. He was promoted to Capt in March and continued to serve in the Middle East until March '42. From there he served in the South West Pacific Area until February 44. He was a foundation member of AEME and then RAEME. At the end of the war when he decided to return to civilian street he held the rank of T/LtCol. He was awarded the 1939/45 Star, Africa Star, Pacific Star, Defence Medal, War Medal 1939/45 and the Australian Service Medal.

**LINSELL & COMPANY PTY LTD**  
(Inc in NSW) ABN 30 002 419 721



**BOLTS & NUTS  
HAND & POWER TOOLS  
DRILLS, TAPS & DIES  
ABRASIVES**

Factory 1  
73 Governor Macquarie Drive  
Chipping Norton 2170

**Ph: (02) 9755 1528  
Fax: (02) 9755 1557**

**ZINABACK PTY LTD**  
*Suppliers of*

• **LIME • GYPSUM • DOLOMITE & blends •**  
**DEFENCE WORK CATERED FOR**  
Phone Vaughan Benn

• **4788 8133 • 0407 634 107 •**  
TOWNSVILLE

*Congratulations the Australian Army on their Centenary Anniversary*

**HITACHI CONSTRUCTION MACHINERY (AUST) PTY LTD**  
*National Distributor of Mining, Forestry and Construction Equipment including:*  
Hitachi excavators, Euclid and Hitachi dumptrucks, Deere/Hitachi loaders, Deere tool carriers/backhoe/ graders and crawler dozers, Protec compaction equipment, Furukawa hammers and mini wheel loaders, Tadano cranes, Timberjack, Hitachi Keech G.E.T. and Donaldson filters

55 Milperra Road, Revesby NSW 2212 Ph: (02) 9780 6900 Fax: (02) 9780 6999

**Forklift Breakdown? Get back to work FAST...**

When equipment breaks down, you can't afford to be off the job for long.

Call Active Fork Lift Service. We respond within the hour and our service vans are stocked with frequently-used parts to slash your down time.

Our dedicated staff live and breathe all makes of fork lifts and we've got what it takes to fix YOURS.

With Active there's no head scratching and NO mistakes. You KNOW it's been done correctly because our technicians follow our strict Quality Assurance checklist.

Best of all, parts and labour are GUARANTEED for three months!

Call us NOW. You'll save money and get back to work FAST!!

**Active Fork Lift Service  
3205 5500**

**All Suburbs  
24 Hours a Day - 7 Days a Week**

Prior to the Second World War a situation had developed where it was not possible to enlist sufficient qualified tradesmen for the Army requirement. A scheme did evolve for the training of apprentices whereby apprentices were attached to large army workshops and attended civilian technical colleges. After the war in a period of expanding industry and full employment, competition for skilled labour and trainable youth was more acute than ever. Investigations commenced and it became evident that a comprehensive training scheme was required, one which provided both civilian and military qualifications.

The document setting out the case for the establishment of a military technical training school was titled "Military Board Agendum No 173/1947 of the 20th October 47 - Formation of an Army Apprentices School" over the signature S F Rowell, Lt General VCGS. The project was considered at a Military Board meeting of 29th October '47, after extraneous aspects of the establishment of the school had been considered in more detail, the Honorable Cyril Chambers, Minister for the Army, gave his approval and within three months the school was founded.

In the meantime, Lt Col F B Oldfield, a technical officer and educationalist with eight years experience in two world wars and at the time conducting his own preparatory boarding school for boys at Wahroonga, NSW, was appointed the first Commanding Officer of AAS on 7 December '47. He immediately became deeply involved in the whole planning process with priority on locating a suitable site. The ideal site was seen as one that was isolated from camps and depots for adult soldiers.

In view of the limited range of choice, Balcombe had much to commend it. It was 36 miles from Melbourne, isolated but not too far from the city and with only two Army units, both schools, already established in the area. Accordingly, the Army Apprentices School was established at Balcombe and Lt Col Oldfield took up residence at Balcombe in February 48.

Selection of apprentices began in May and on 2 August the first intake of apprentices took possession of the camp



Balcombe gates

which during the Second World War had received the battle tired United States First Division straight from action against the Japanese in the Solomons.

The camp was badly run down, it needed renovation, maintenance and extensions. Trained staff and more equipment were both in extremely short supply. Post WW2 reorganisation of the Australian Military Forces was taking place and competition for men and materials was keen.

The opening of the new school before accommodation and equipment were prepared and before the establishment of trained instructors had been provided was a bold move. Perhaps not altogether justified in the circumstances, but Lt Col Oldfield argued that an early opening would give substantial impetus to its completion as a going concern and the securing of the necessary staff. In addition, it was accepted that a good deal of self-help on the part of the first intakes of apprentices in setting up the camp was inevitable. Reporting on progress during the first twelve months, Lt Col Oldfield stated in August '48 that the total enrolment of apprentices for the year was 63. Although it was decided to take the full planned intake of 150 in January '49, the CO expressed his relief that the actual intake was only 80, as building alterations had not even begun, furniture and floor coverings had not been supplied, staff had not been

increased and the new number of students (80) seriously overtaxed available resources. It became common practice for apprentices to be tasked with all manner of jobs such as painting buildings, digging drains and this type of training was referred to as "Practical Engineering". In the CO's report dated 21 June '50 he stated "Our first intake boys (Electrical Trade Apprentices) will begin their last year's training without having set foot in a workshop or laboratory". During this period he was awarded the Australian Efficiency Decoration for his pre WW2 CMF service.

Times were tough, resources were scarce but when Lt Col Oldfield handed over command of AAS he had achieved excellent results and established the foundations for a school that supplied the Army with tradesmen for some 46 years. He was described as a wise and humble man of many and varied talents who was prepared to take what steps were necessary to ensure the initial success of AAS.

Lt Col Oldfield handed over command of AAS in July 52 and in September of that year he resigned from the army for the third time with the rank of Honorary Colonel. To make use of his journalist skills he was employed as editor of the *Mornington Post* for some years before he returned to Mosman where he taught at the TAFE until his death in October '62.

### Transpacific Industrial Solutions Pty Ltd

7 DAYS - 24 HOURS

- Roadsweeping • Industrial vacuuming • Drain cleaning and CCTV surveys
- Sand blast and paint • Protective coatings • Shut down cleaning specialists
- Facilities management

AUSTRALIA WIDE:

Rockhampton, Gladstone, Brisbane, Darwin, Townsville, Sydney, Melbourne

**Phone: 1300 790 200**

### TOWNSVILLE TRUCK ELECTRICS

HEAVY TRUCK ELECTRICAL & AIR CONDITIONING SPECIALISTS

ON SITE SERVICE

PH OFFICE 4788 0026

MOB: 0428 777 406

# article



**Museum Manager: Major Graham Docksey, OAM (02) 6055 2833 • Collections Manager: Neil Dailey (02) 6055 2234**  
**Museum Shop and General Inquiries: (02) 6055 2525 or Fax (02) 6055 2886**  
**E-mail: bandiana.museum@defence.gov.au • Web address: only on the Defence Restricted Network at this time**  
**Open to the public Sunday to Friday 9.30am to 4pm**

## Vision

The Army Museum Bandiana will provide a leading edge focus for the interpretation and public display of Australia's rich Military Heritage, with a special emphasis on the history of the Army's logistic corps.

## Mission

The Army Museum Bandiana is committed to best practice in the preservation, management and display of its collections in order to protect and preserve Army's heritage and to promote its history to the public.

## What has been happening in the museum?

Another busy six months for both staff and volunteers as we drive ahead with the museum development program. We are steadily proceeding with the introduction of museum best practice meth-

ods across the museum. The interpretation of displays, storage methods, lighting levels and paint applications are now a part of our planning process with the development of new displays.

The establishment of a new display for the Australian Service Nurses has been completed and really showcases the tremendous contribution and sacrifice made by Australian Service Nurses since their formation in 1899. Uniforms from the Boer War, both World Wars, BCOF Japan, Vietnam and today are on display. The valuable contributions made by the Volunteer Aid Detachments and the Red Cross have also been recognised within the display. A must to see.

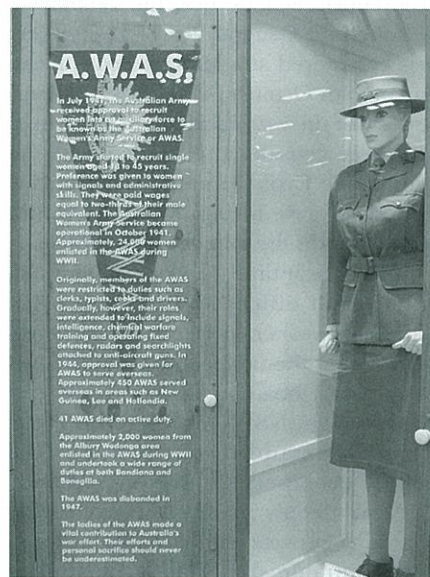

**AWAS uniform 1942**



**The Australian Women's Army Service display**

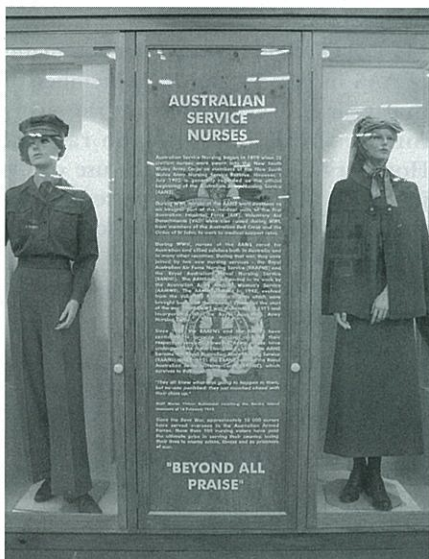

**Boer War Nurses uniform**

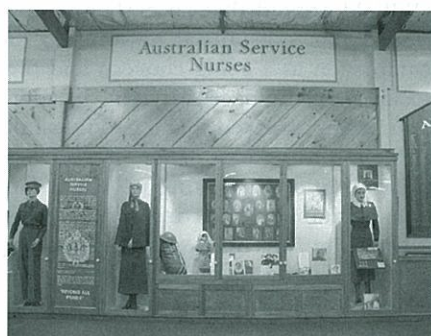

**A section of the Australian Service Nurses display**

Refurbishment of the Australian Women's Army Service (AWAS) display has recently been completed. Three honour boards listing the names of approximately 2,000 AWAS's who served in the Albury and Wodonga area between 1941 and 1945 have been refurbished. The refurbishment of the honour boards and the painting of several new signs were funded by the Department of Veterans' Affairs under their community grants program 'Saluting Their Service'.

## Get to know the staff: Neil Dailey

Neil started work as the Collections Manager in January 2003. He comes to the Museum with many years experience in the museum industry including Museum Technical Adviser at the Army History Unit (AHU) in Canberra, Curator at the Fort Queenscliff Museum as well as Executive Board Member of



Neil at work on MAJGEN Gerguson's uniform

the Community Museums Special Interest Group. Neil has a Graduate Diploma in Museum Studies and plans to complete a Masters Degree in Cultural Heritage in 2004. Neil also has 20 years experience in the Army. He has been an Air Defence gunner since 1983. Neil's overseas service includes a six-month stint in England, a deployment to East Timor as well as a trip to Afghanistan for the Army History Unit. Once he becomes a Public Servant on the 6th of December, Neil will transfer to the Active Reserve in the familiar position of Museum Technical Adviser at AHU. Neil is married with three children and plans to settle in the Wodonga area.

**Get to know the volunteers:  
Ray Hartwig**

Ray has been an active volunteer for 12 months and finds the work as he says 'great fun', 'fantastic' and 'different from one day to the next'. Ray retired from V Line in 1995. In his earlier years he was a member of the Citizens Military Force in Melbourne and served at one time with 8/13 VMR. At present Ray is working each Thursday on a vehicle first parade-servicing program. The vehicle fleet numbers in excess of 100. Ray is also on the weekend museum-opening roster and is always prepared to assist on other occasions as and when the need



Ray inspecting a World War Two Mobile Workshop Truck

arises. Volunteers are essential for the operation of the museum on weekends, public holidays and on other special occasions. Volunteers like Ray allow the museum to continue with the development plan. More volunteers are always welcome across a number of vital areas.



The new education room

Work is nearing completion on the new Education Room within the museum. The room was developed by relocating the weapons display closer to the ticket office for visual observation by staff. The education room will provide a venue for the conduct of presentations to special interest groups, schools groups, military members and service clubs in conjunction with their visit to the museum. The museum is grateful to the following companies for their support with the establishment of the room:

The Commercial Club Albury, Peter Middleton's Carpets Wodonga, Sebel Furniture Canberra, Wattyl Paints Wodonga, Border Heating and Cooling Wodonga and Spotless Services Bandiana.



Construction of a new vehicle shelter for the museum's collection of Recovery Vehicles is nearing completion. The recovery collection includes a Centurion Armoured Recovery Vehicle, Landrover light recovery vehicle, and a number of single and twin boom wreckers. This shelter brings the numbers of vehicle shelters now to six. During the next few months these shelters will see the heavy vehicle display established and opened for visitor access in the second half of 2004.



The entrance foyer of the museum has recently been updated and includes the photographs of all 96 Australian recipients of the Victoria Cross as well as a brief history of each of the eight Corps that form the Army Museum Bandiana.

**The museum shop**

The shop stocks a range of Corps items including plaques, ties, thermal mugs, Corps statues, coffee cups, mouse mats, Corps history books, stubby holders, tie tacks, tie clips, Corps prints, collectors tea spoons and much more. Ring and find out more. (02) 6055 2525 and ask for Bryan.

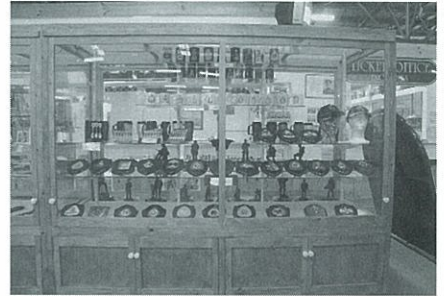

**Continued development projects**

Work is continuing on the refurbishment of the RACT, RAAOC and RAEME display areas.



A section of the RACT display featuring the new information wall panels



The RAAOC wall now featuring the 'from the factory to the foxhole' mural



A section of the RAEME display featuring a gun repair task in the field in Vietnam

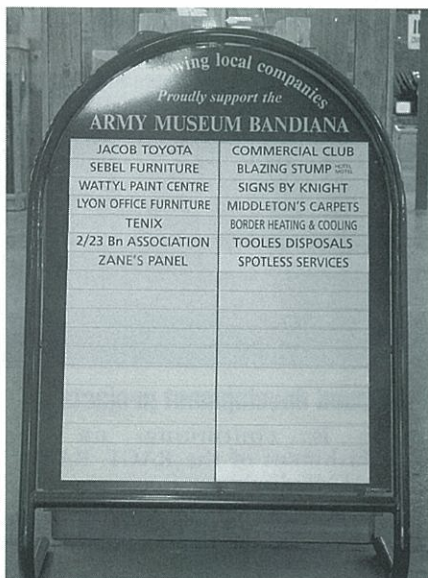

The museum is proud to be supported by the businesses listed on our supporter's board



Museum vehicles being used in a parade in Wodonga on Saturday 20 September 2003. Mr Ted Kenna, VC in the 1958 Ceremonial Landrover on the left



World War One & Two display cabinets



Ceremonial Series Three Landrover

# Basic Recovery Course 0003



Front row: CFN Thompson, CFN Roberts, CFN Parker, CFN Del-La-Mare, CFN King, CFN Herwig, CFN Ingleton  
Back row: PTE Marchant, PTE Wicks, CFN Bortot, CFN Clifford, SGT Raith,  
Instructors: SGT Venables, WO2 Yates, SGT Roberts

How does one put five and a half months of training into so few words? We could carry on about all the technical shit we learnt, but we had basically forgotten it by mornos the next day.

Some of the highlights of the course that do come to mind though (probably the ones the instructors want to forget) would be; modern art on the chain saw course, trying to decipher SDSS, blowing holes in desks with OXY/Acetylene, and dead wombats on the 1st three-day drive.

After all that we finally cracked on with the lift towing, using MRV and Mack. Much to the instructors disappointment, and ours the mythical HRV did not show its head this time. (Will it ever?)

Once we where done with towing, it was on to the extrication phase (that's winching for all you Boffens). Compensating tackle was used to the best of its ability in some tasks and was just along for the ride in others.

Now that we have borred you with all



F1 Dump being recovered at R&R during "EX Help Required"



WO2 Gallagher enjoying the view and his Tax Free Dollars

the work related stuff, here's some of the extra curricular thing's we got up to.

- Del learnt what a black run was on the ski slopes.
- Marchy fell in love and impressed us all with his hotted up car
- Kingy found that age is a boundary when it comes to anything electrical
- Parksy kicked every ones arse at Halo
- Borto kept us entertained and the tyre companies in business
- Wiggy taught us all how to drink

- Ingo was not impressed with the quality of meat at any of the BBQs
- Tomo Baffled us with Scottish humour
- We all tried to work out what Sgt Raith was saying. (But couldn't.)
- Cliffo was working on his super saiyan powers most of the time
- Wicksy enrolled in Clown school
- And Robo kept on being Robo.

In the last weeks of the course we completed our sub 2. Some people got lost time and time again on the nav phase. Hats off to Cliffo for doing 2 laps of his nav leg and we won't talk about any rovers that got up on 2 wheels.

In closing, we would just like to thank the following guilty parties for getting us through.

WO1 "Dead wombats!" Spargo

WO2 "Just keep bloody winching." Yates

WO2 "You've been out all night again." Gallagher

SGT "XXXX question time" Roberts

SGT "It's not Darwin weather." Stewart  
SGT "If you wanted kids, you could have had one of mine" Venables

And last but not least MR Greg "Don't bloody lose it." Cross.

Well that's all from the 0003 Basic Recovery Mechanics Course. Hope to see you all on the road some day. (Preferably not broken down)

*You Maul, We Haul.*



Joy oh joy! Ground anchors aren't they fun! Wait till they have to remove these!



Nice Day for a Drive through the Victorian Alps

## Army Personnel Agency – Townsville

**W**hy are there RAEME personnel at an APA when they're more likely to be found in a workshop or a technical environment? There are two RAEME personnel currently posted to APA-T. They are MAJ Michael Lunn and SGT Michael Maloney.

MAJ Lunn is a reservist who came to APA-T from 11 CSSB, where he was OC 108 FD WKSP COY. MAJ Lunn now has the job as the SO2 Plans.

SGT Maloney finished up at JLU (NQ) and separated from the ARA after 25 years, transferring to the Standby Reserves (SRes) in Jan 03. He came to APA-T initially employed on a DA50 (4) whilst waiting for a position at the Queensland Police Academy in the May 03 intake – Townsville. That's not happening until February 2004, so he transferred to the Active Reserves (ARes) and was posted to APA-T as the Retention Sergeant. His job entails managing the Standby Reserve (SRes) personnel living in the NQ Region.

Any of the following sound familiar?

"The Army's \*^&@#",

"I've had a gut-full",

"I hate the Army",

"I've had enough of being \$@&\*~+ around",

"How do they expect their equipment to be ready when we have to do this bull\*!@?", and

"I'll get a job in the mines, etc".

Here is a "plug" for the SRes aimed at all ranks that are considering taking discharge or resignation from the ARA or ARes. Why not transfer to the SRes instead? The soldier tends to initiate a fair percentage of discharge action as a



MAJ M. Lunn & SGT M. Maloney

cumulative result of minor occurrences – but these should not ruin latter opportunities. We would like to suggest that rather than separate completely, transfer to the SRes. This will enable you to have a break from your ARA or ARes service and re-consider your views and options.

Should you decide that life on the outside is not as rosy as you thought it might be, it is far easier to transfer back to the ARA or ARes from the SRes than it is to go through all of the re-enlistment/ re-appointment procedure again. At least this way, you will be able to "keep a foot in the door" so to speak. There are numerous vacancies for all trades in the ARes located in the NQ region. As a multi-skilled member of RAEME, it is highly likely that you will have other skills which will enable you to be more readily employed by your preferred unit should there be no listed vacancies for your rank/ECN.

Why should you transfer to the SRes instead of discharging? There are a few

incentives for serving in the SRes, and they include and are not limited to the following:

There is no obligation to parade as you are not posted to a unit. It's something like being on long service leave – but without the pay!

It is easier to transfer back to the ARA or ARes from the SRes than to go through the entire enlistment process again should life on the outside be not as rosy as first thought;

There is no requirement to be AIRN compliant whilst in the SRes (no BFAs/ CFAs, etc);

There is the opportunity to be employed on a short term contract, known as a DA 50(4), for up to 100 days per financial year should you have some free time and a desire for tax free money. This will enable you to have an income stream whilst you are in the process of finding alternative employment after separating from the ARA/ARes, or if you are unable to commit sufficient time to serve with the

ARes due to other commitments; and

The only obligation you have to service in the SRes is to maintain contact with your APA once yearly as a minimum.

As a reservist you are eligible for certain financial benefits connected to Defence Health and the associated Term Life Insurance.

If you do decide to transfer to the SRes instead of discharging/ resigning, information is available from your Unit Re-settlement Officer, unit orderly room,

or contacts your region's APA for advice. Contact phone numbers for the regional APAs are as follows:

- APA – Adelaide (08) 8305 6373;
- APA – Brisbane (Offr) (07) 3233 4238; or (07) 3233 4502;
- APA – Darwin (08) 8935 4989;
- APA – Hobart (03) 6237 7169;
- APA – Melbourne (Offr) (03) 9282 4061; or (03) 9282 6227;
- APA – Perth (Offr) (08) 9311 2334; or (08) 9311 2348;

APA – Sydney (02) 9339 3248; and  
APA – Townsville (07) 4726 0283.

Once you have spent some time as a Standby Reservist and you think that the ARA/ARes wasn't so bad after all and you have some spare time to commit, why not transfer to either the ARA or ARes. Contact your APA and talk to them and find out what jobs are open. The other options you have are to either continue serving with the SRes, or take discharge/resignation.

# AUSBATT 8 – Story of the RAEME flag, BGR Dili Timor Leste

By WO2 Craig Pereira  
ASM BGR Dili

**W**hen Ausbatt 8 arrived, with them came a RAEME flag, which flew high and proud over the workshop. It was thought that it would be stolen by any of the other corps around. So in true RAEME tradition a plate was placed over the halyard, tek screwed through the mast and welded to mast. The mast was then welded to the top of a container.

As predicted, people tried to remove the flag, and for a while no one succeeded. One night, some scum sucking lowlife cut the flag from the halyard and all hell broke loose. People were accused and abused but in the end no-one was game to own up.

On 21 Jun 03, the OR's at BGR held a dining in night. As everyone was mingling with their pre-dinner cordials and cokes, the following sight appeared.

*Arte et Marte*

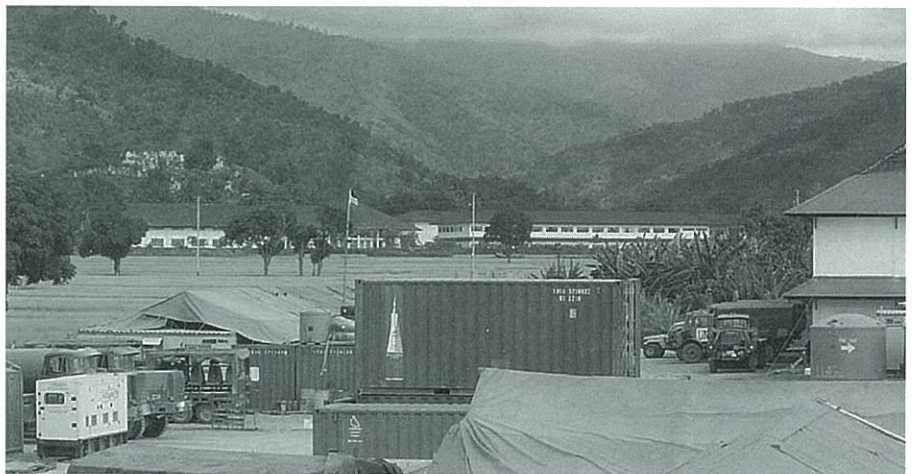

**Tri-City TRUCKS PTY LTD**  
**4647 4488**  
 Fax: 4646 1205  
 335 Camden Valley Way  
 Narellan  
 PO Box 39, Narellan 2567  
 Workshop open: 7am to 8pm, Mon to Fri • Parts open: 7am to 8pm Mon to Fri • Fax: 4647 4485  
**EZY-PARTS for ISUZU – HINO – UD**

**KS KERR SOLUTIONS**  
**Virus Removal/Data Recovery**  
 New Systems & Upgrades  
 Virus Prevention  
 On-Site Service  
 Custom Computer Configurations  
 File Servers  
 Extended On-Site Warranties  
 Data Backup Systems (On & Off-Site)  
 Networking  
 Computer Peripherals  
 On-Site Set Up & Training  
**4926 0753 – 0418 260 753 (Bruce)**  
 Rockhampton  
 Email: admin@kerrsolutions.net

# article

Surname .....

First Name .....

Rank..... PMKeys Number .....

Unit..... Appointment .....

Address (Postal Address for Miniature) .....

.....

.....

..... Postcode .....

Contact Number: ( ) .....

Email Address: .....

Number of Miniatures @ \$160 .....

Preference for Miniature # "No Guarantee" .....

Total Cost: \$ .....

Payment Enclosed of ..... Paid by (Method) .....

Cheque/Money Orders to: RAEME Corps Fund .....

Signature..... Date .....

Only Quantity 200 in the *Foundation Issue* @ \$160. Future issues will be plus 20%  
Order forms (complete with payment to be sent to:  
MAJOR Graham Anderson, SO2 Corps – RAEME, Head of Corps Cell, Latchford Barracks,  
MILPO BANDIANA, Vic 3694.  
Email: graham.anderson@defence.gov.au. Phone (02) 6055 4308, Fax (02) 6055 2436

# RAEME Corps Port



article



## Director Tawny

Featuring BRIG Field, our first Corps director and listing all Directors/Heads of Corps. A fine Buller and Son Rutherglen fortified, including a collectors miniature for just

**\$15**

POC: Major Graham Anderson  
SO2 Corps – RAEME  
Head of Corps Cell  
Latchford Barracks  
Bandiana, Vic 3694  
Phone: (02) 6055 4308  
[graham.anderson@defence.gov.au](mailto:graham.anderson@defence.gov.au)

# Prince Philip Banner Miniature

The framed miniature is a limited numbered series restricted to currently serving and ex-serving members of the Corps.

The miniature is a quality replica of the Prince Philip Banner.

Each miniature will be individually certified and numbered within a limited numbered series. The size of the miniature is approximately 240mm x 360mm.

The POC for Banner miniatures is MAJ Graham Anderson, details above.



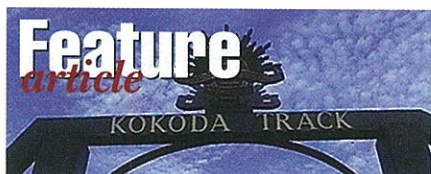

# Kokoda Adventure 2003

*“A little bit up, a little bit down”*

**28 June – 14 July 2003**

**T**he Kokoda Track is sacred ground. It is a place where young, inexperienced Australian soldiers halted the advance of an overwhelming enemy that had not as yet tasted defeat. As if being vastly outnumbered by elite enemy soldiers was not enough, there was also the terrain. Vicious terrain of gut pinching ascents and muddy, bone jarring descents. A place where everything wants to bite you or sting you or both. It certainly is a harsh environment, just how harsh our small group was soon to experience first hand.

To the uninitiated, Port Moresby can come as a bit of a shock. Armed with a limited vocabulary of a few apinun's and tenk yu tru's, our small group from Townsville's 3rd Brigade soon found itself very much in the minority. As we departed the airport we were greeted with run down buildings alongside affluent, razor wire encircled hotels, surrounded by dozens of locals going about their daily business, and it seemed strange that a country closer to Townsville than Sydney could be so different, both culturally and economically.

We headed for the Gateway Hotel, where we sorted out some admin details and introduced ourselves to the remainder of our group who had flown in from Sydney the previous day. One of these people, Maj John Thurgar, an army

reserve historian from Canberra, was our guide for the trip. Two local lads, Linus and his cousin Louis, were also coming along.

Once we had tidied up our admin points we took a ride in our hire cars to our overnight accommodation, the Australian Trade Commissioner, Mr Greg Hull's place of residence. Greg, a retired LTCOL, welcomed us in into his house and, in true expat style, put on a huge BBQ and plenty of cold South

Pacific Lager. The view from his balcony was awesome, overlooking Port Moresby CBD and beyond to the bay. As the sun set it was quite an idyllic setting to sink several coldies, but we had an early start the next morning which saw most of us limit our intake to a few.

It was still dark as we checked in our packs at the domestic terminal. We had chartered a plane to fly us in to Kokoda, and as we squeezed our way into the tiny Twin Otter, twelve months of anticipa-





Isurava Battle site

tion for this trek was finally coming to a head. The little plane struggled to gain altitude, but we eventually punched through the low-level cloud and were greeted by a view of the Owen Stanley Ranges. Even at this height they looked intimidating; razor edged ridges clad by a seemingly impenetrable jungle.

The plane bumped and bounced along the airstrip and came to a stop in front of growing crowd of curious locals. We grabbed our ridiculously heavy packs and walked up to the village of Kokoda. Time was spent perusing the memorial and museum. Peter spoke about the battle of Kokoda and actually seeing the ground really brought it to life.

We departed Kokoda amidst plenty of waves from the locals. The going was easy and the pace slow as we walked through an old rubber plantation, slowly acclimatising to the humid conditions. As we approached Kovelvo village some local kids halted our progress. They informed us that their village was not ready for our arrival, which confused us somewhat. We waited a few minutes and then continued and as we

approached the village the chief and some women, all dressed in traditional tribal attire greeted us. They were all set to perform a dance for us until they figured out that we were the wrong group, and that their paying visitors were the group about an hour behind us. So we missed out on the dance but we were allowed to take some photos, for a few Kina of course! It seemed the Kokoda Track tourist business was alive and well.

It was here that we also picked up our third guide, Scotty. He was an old friend of Linus and was keen to come along, so he threw a few belongings in an old

Coca-Cola backpack and in less than two minutes was ready to go.

One thing that must be noted is that there are a few local Rascals on the Track who have a fairly relaxed attitude towards law and order. So with this in mind our guides were sleeping with their ears open on our first night, just to be sure we hadn't been followed into the jungle. Later that evening Shane, returning from a call of nature, unwittingly stumbled into a machete wielding, screaming Linus who was hell bent on protecting the group from this intruding "Rascal". Luckily, Linus recognised the girly whimpers of fear as those of Shane and carnage was avoided.

The first highlight of the trek was the Isurava Memorial. Upon our arrival at Isurava we were greeted by the locals, who were only too willing to sell some of their fresh produce including kau kau (sweet potato), mandarins, passionfruit and bananas. All this for only a few Kina, a bargain at half the price!

The memorial, which was recently opened by Prime Minister Howard, is really something and a credit to all



involved in its creation and maintenance. It is sited right on the battleground, and although the area has been extensively cleared weapon pits still remain. It was here in August 1942 that the Australian Maroubra Force halted the Japanese advance for four days, and PTE Bruce Kingsbury earned the Victoria Cross.

Our group spent the afternoon giving presentations on different battles of the campaign, and watched the sun set over this sacred piece of ground.

A couple of days into the trek we experienced creek crossings “Kokoda style”, the first being at Eora Creek. This fast flowing creek was spanned by a suspension bridge manufactured from saplings lashed with vines. With the bridge swaying and the rushing water below the confidence levels of a few members of the group was really tested.

By this stage of the trek we were well in truly in the swing of things, and some repetitive answers to typical questions were being offered by our guides; for example:

Q: “What’s this stretch of track like?”

A: “A little bit up, a little bit down”.

Q: “How much further ‘til the next water point?”

A: “100m”.

Q: “How much further ‘til the next camp?”

A: “100m”.

We were learning a lot from our guides, in particular about bush tucker. Questions were fired at Linus continually about what was edible.

Q: “Can you eat this?”

A: “No”.

Q: “Why not?”

A: “It’s a stick”.

At about the trek’s halfway point lay Mount Bellamy, the highest peak on the track. It was a continuous uphill slog that took a couple of hours to conquer. There was a sense of achievement amongst the group; after all if this was the highest peak it had to be all downhill from here, right? That’s what we told ourselves anyway.

Ita had by now perfected a rather unique method of descending the slippery slopes. She had practised it during the lead up training on Mt Stuart

behind Lavarack Barracks, but was now employing it with consummate ease. It consisted of utilising part of her anatomy, dubbed the “Downhill Negotiating Device”, aka her arse. A slow but sure way of avoiding a tumble.

Nabby, however, did not believe the track was slippery at all. He stated that slippery to him was a pane of glass covered in Vaseline and KY jelly, and that he couldn’t understand why people were slipping so often. Not five minutes after making that statement Nabby slipped on the only Vas and KY covered sheet of glass on the whole track.

Huck had his own theory on how to beat the slipperiness; the good old KT26 running shoe. He claimed that the tractor like tread on the Dunlop favourite would keep him upright, and that dozens of KT26 wearing PNG locals couldn’t be wrong. If only he had brought them along.

Up to this point we were blessed with perfect weather, so we couldn’t complain when we finally got an afternoon downpour at our night four camp at the Morseby side of Mt Bellamy. When the



Group crossing a log

rain eased we gathered around the fire for the usual talk of the days events. Louis, who was initially very shy, was coming out of his shell, and decided to teach Macca and Stu a song in Pidgin. It took a while, but the boys were soon in fine voice, and “entertained” the group well into the night.

We continued on the next day through the villages of Naduli, Kagi and Efogi 2 and received the usual warm welcome from the locals, and more fresh fruit and veges which was always a pleasant change from the packet tuna and Deb potato or rice.

We camped at Efogi 1 on night five at a guesthouse, which was complete with a long drop toilet and shower. As we had arrived mid afternoon, we had plenty of time to wash, cook up, relax and talk the usual bull. Some of us also did a bit of a stocktake on remaining food supplies. Nabby assured us that his one muesli bar and half a packet of beef soup was plenty to see him through the remaining four and half days. We also discovered why Macca and Ita’s packs were so heavy; it appeared they had brought enough tucker for a month! Nabby soon alleviated some of this excess burden.

The next day saw us climb up to Brigade Hill, the site of fierce fighting in September 1942. At that stage of the campaign the Japanese South Seas Detachment had received even more reinforcements, and outnumbered the Diggers six to one. Out-numbered and out-gunned, the Australians were once again forced to withdraw. They lost about half their number on that place

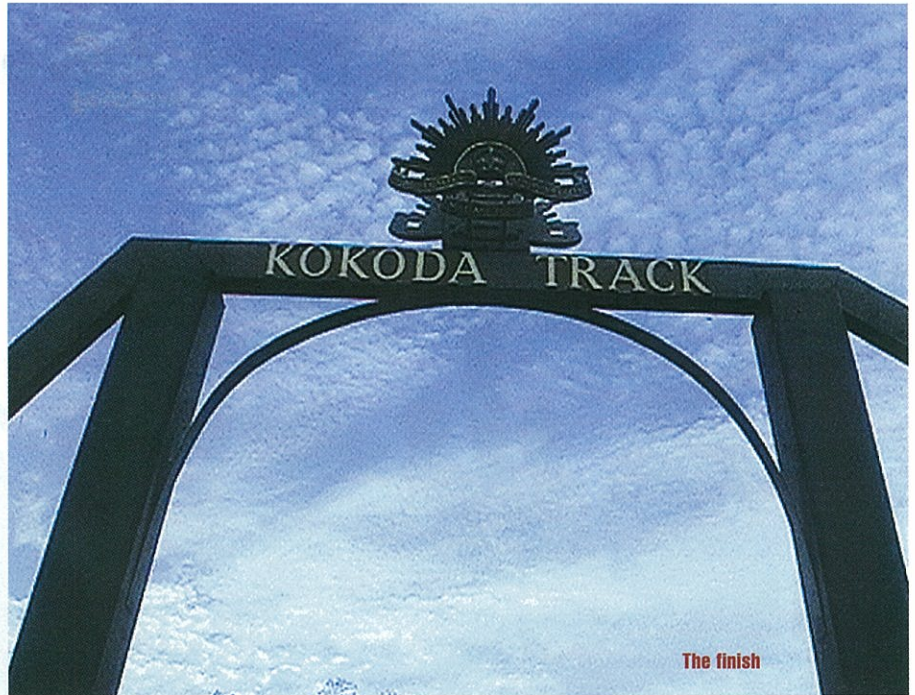

the Diggers renamed “Butcher’s Hill”.

We sat on the side of the Track, in about the same position of Brigade HQ all those years ago, and listened to Shane and John’s presentation on the Battle of Brigade Hill.

We camped at the village of Menari, where we enjoyed a swim in the creek and a relaxing afternoon. That night we were treated to a concert performed by the local kids. Even in the dark of the night their beaming smiles were evident for all to see.

By the time we reached Naoro village word had got out that a few of us were keen to try wild pig, so the local fellas

obliged and caught four suckers. They were butchered with a sharp knife and a machete and the pieces cooked the traditional way wrapped in banana leaves and placed over hot rocks. We were also given some fresh cooked veges to top off the feast. The night was completed with another performance from the local kids.

The end was now in sight, only a couple of days to go. We had by now learnt to ignore the chafing, aching legs and blisters. We climbed up and over the Maguli Range, criss-crossed Ua Ule Creek umpteen times and then, on the second last day, we were faced with a daunting climb up Imita Ridge. We had a breather on top of the ridge at Imita Gap before starting the descent down to Goldie River.

This part of the Track runs parallel to the original Golden Staircase. There had been a few local downpours in the area, and the Track had been turned into a quagmire; panes of KY smeared glass everywhere you stepped. A new club was formed amongst our group, dubbed “Fall Club”. Membership criteria was simple, all you had to do was make contact with the ground with your hand, or in Ita’s case her buttocks. Membership numbers increased quickly as we slipped and slid our way down to Goldie River.

We made an overnight camp on the banks of the Goldie, our last night on the Track. Most of us tucked into all our remaining food and then as the rain started to fall again settled in for the night, thanking God for bivy bags and hootchies.

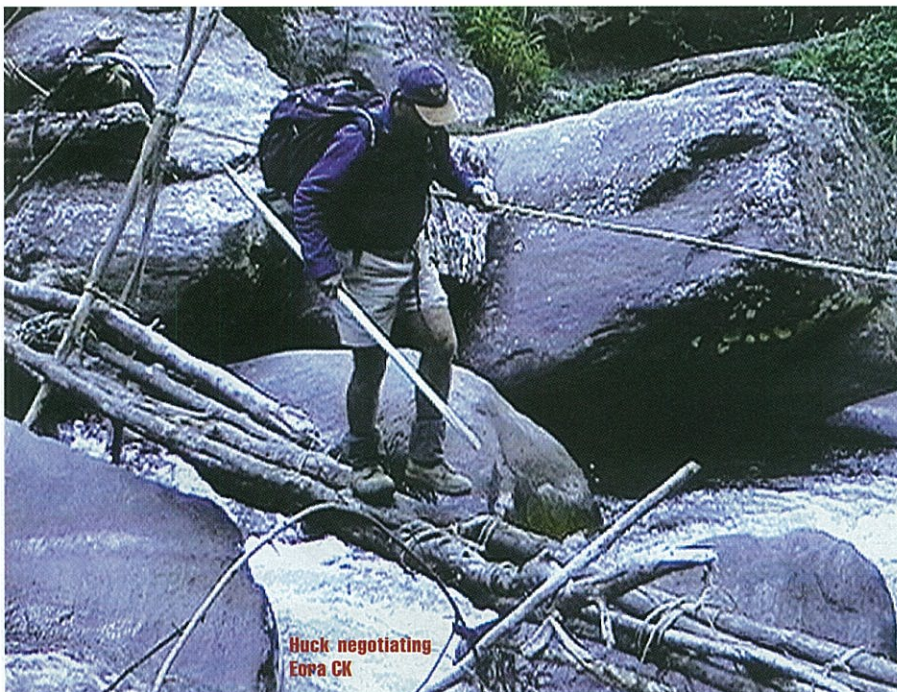

# Kokoda Track Adventure July 2003



Back row: Barry, Ita, Peter, John, Hedonna, Richo, Macca, Katie, Huck, Louie. Front row: Nabby, Jim, Scotty, Shane, Stewie, Linus

The climb out of the valley up to Ower's Corner was certainly steep, but hardly noticed by the group members. As we neared the top the jungle gave way kunai grass until the Track took a bend and there before us stood a huge gateway, embossed with the words "KOKODA TRACK". It was hand shakes and smiles all round as each of us made our way under the gateway and on to the manicured lawn of the Ower's Corner memorial garden.

We had done it, conquered the Kokoda Track. But did we really "conquer" it? We had good food, great equipment and were all in good health. We were also blessed with good weather, which kept the Track dry for the majority of its length. And, obviously, there wasn't the constant threat of being killed at any time. Yet we still found it to be a challenge.

How on earth those young Australians of the Maroubra Force defeated an overwhelming enemy in such hostile terrain is something none of us could fathom. Courage, endurance, mateship and sacrifice are all words that are at times

are used too freely. But there are no more fitting words to describe those Diggers who halted an aggressor at

our doorstep, and ensured that we today live in undoubtedly the best nation on Earth.



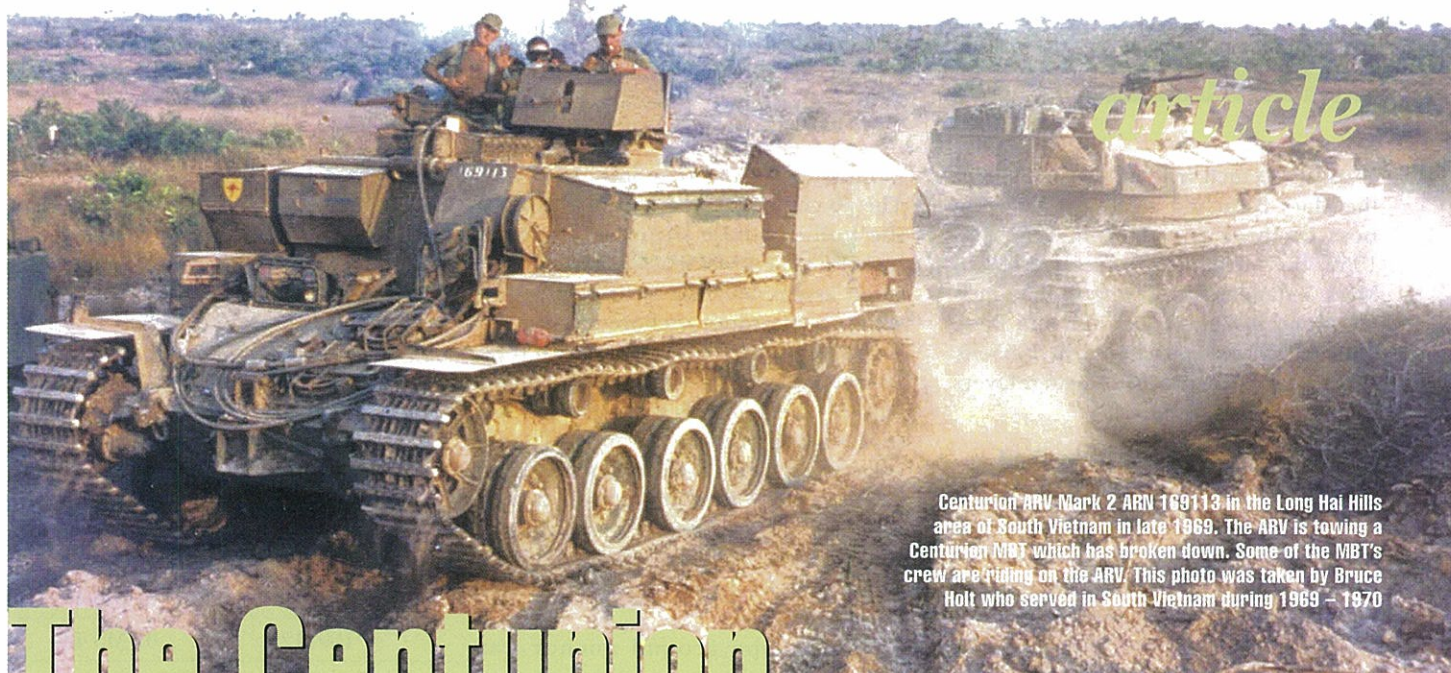

article

Centurion ARV Mark 2 ARN 169113 in the Long Hai Hills area of South Vietnam in late 1969. The ARV is towing a Centurion MBT which has broken down. Some of the MBT's crew are riding on the ARV. This photo was taken by Bruce Holt who served in South Vietnam during 1969 - 1970

# The Centurion Armoured Recovery Vehicle in RAEME Service

By MAJOR Paul Handel

## Introduction

The Centurion Armoured Recovery Vehicle (ARV) Mark 2 served in RAEME for just over twenty years, from 1956 until 1977. During this time, some of them accompanied the tank deployment to South Vietnam between 1968 and 1971. A large, heavy vehicle with none of the power operated booms and anchor spades seen on today's recovery vehicles, they were nonetheless admired by their crews for their robustness.

RAEME also used one Centurion ARV Mark 1 which was acquired from New Zealand in 1969 and issued to the Armoured Centre Light Aid Detachment during the last years of the Centurion's Australian service.

## Centurion Tanks in Australia

The Centurion family of vehicles was developed towards the end of the Second World War by the British as their first "universal" tank. It was meant to replace the myriad of light, cruiser, medium and heavy tanks then in service and to combat the current German tanks such as the Panther. The first prototypes arrived for trials in north-

west Europe just in time to see the end of the war.

The Centurion Main Battle Tank (MBT) was first introduced into Australian service late in 1951 and replaced the ageing Churchill tanks with which the 1st Armoured Regiment was equipped. The Centurion was the first tank in Australian service to be fit-

ted with a fully stabilised gunnery system, and used the 20 pounder gun as its main armament.

An initial purchase of 60 Centurion Mark 3 tanks was made from the UK in 1949-50, and later in 1955-56 a second purchase of 57 Centurions was made. This second purchase comprised all Mark 5 models, identified by having a



One of the first Centurion ARV Mark 2 to arrive in Australia during 1956. The vehicle is being carried on a Dyson 50 ton Tank Transporter trailer towed by an M20 Diamond T Prime Mover

co-axial .30 inch machine gun, whereas the Mark 3 carried a co-axial 7.92 mm Besa machine gun. During 1955 and 1956, the Mark 3's were converted to Mark 5 standard by having the .30 inch MG fitted in lieu of the 7.92 mm Besa. Four ARVs were purchased in 1955-56, two in 1956-57 and four bridgelayers were purchased in 1961.

**Centurion ARV Mark 2 Described**

The Centurion ARV Mark 2 was a Centurion tank without a turret and main armament. In its place was a large box-like structure which housed the winch equipment. This armoured structure had a standard tank cupola mounted on the top left side and a double hatch on the right. Access doors were also placed in the rear of the structure. The entire top of the winch compartment could be removed to allow access to the winch. The space adjacent the driver had also been modified to mount an additional fuel tank.

The winch engine was a Rolls Royce B 80 8 Cylinder in-line petrol engine which drove a generator, which in turn provided electric power for the winch. The winch used a horizontal drum with 137 metres of 28.5mm steel wire rope. The winch had a direct pull capacity of 30 tonnes, which could be increased by the use of snatch blocks carried on the vehicle.

A lattice boom crane jib was also carried on the tank, in two parts and

mounted over the rear stowage boxes. The jib could be erected on the front of the hull, the base sitting in a special socket on the lower glacis plate. The jib, when assembled, was held in position with two stay ropes anchored back to each side of the vehicle. The winch rope was reeved from the winch compartment and over the fairleads at the front of the superstructure thence to the jib. The jib was actually rarely used in Australian service, especially after the introduction of the M543 wheeled recovery vehicle and the M113A1 Fitters Vehicle, both of which were equipped with hydraulically operated cranes.

A spade-type ground anchor was mounted on the rear of the hull, and fairlead assemblies allowed the winch to take pulls off the centreline. Various fittings on the hull allowed the return run of the winch rope to be anchored to the vehicle, and it had the ability to tow a laden main battle tank. The spade anchor was a large robust unit, and owes its origins to the German Bergepanther of the Second World War, possibly the best armoured recovery vehicle developed during that period. A rear jib was fitted over the spade assembly, but this was not used for lifting purposes as was the front jib.

**Centurion ARVs in Australia**

The six Centurion ARV Mk 2 were purchased from the United Kingdom, and, unlike the MBTs which came direct-

ly from British Army stocks, the ARVs were taken from equipment especially set aside for sales to foreign customers. Hence the ARVs when acquired carried British registrations with an MS for military sales. They were given Australian Army Registration Numbers (ARN) on arrival in Australia and the table below shows the equivalent numbers:

Australian Army Registration Number (ARN)	United Kingdom WD Number
169111	01 MS 45
169112	01 MS 43
169113	01 MS 42
169114	01 MS 44
169121	01 MS 97
169122	01 MS 98

ARVs were issued to the 1st Armoured Regiment Light Aid Detachment and the Armoured Centre Light Aid Detachment, both based at Puckapunyal, and to the RAEME Training Centre at Bandiana.

**Centurions in South Vietnam**

Australia first committed advisers to South Vietnam in 1962, and in 1965 the first combat troops were deployed - an infantry battalion with a troop of M113A1 Armoured Personnel Carriers

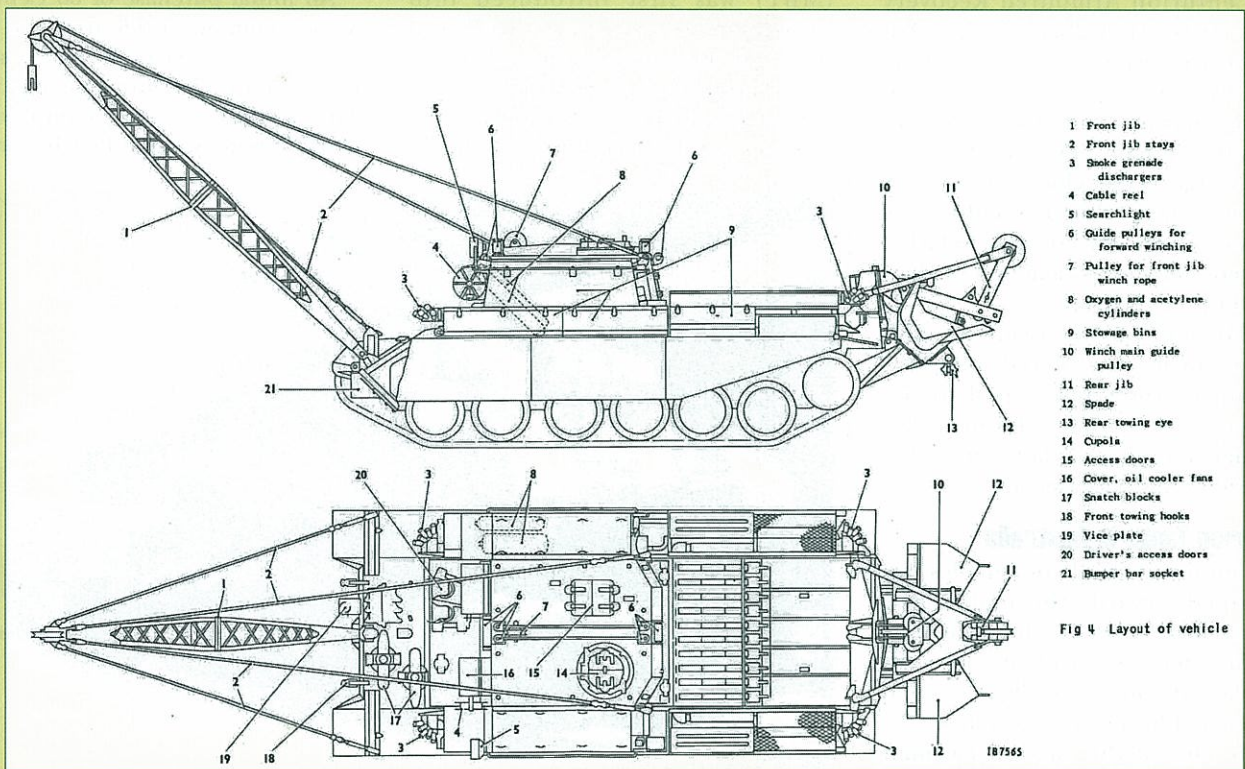
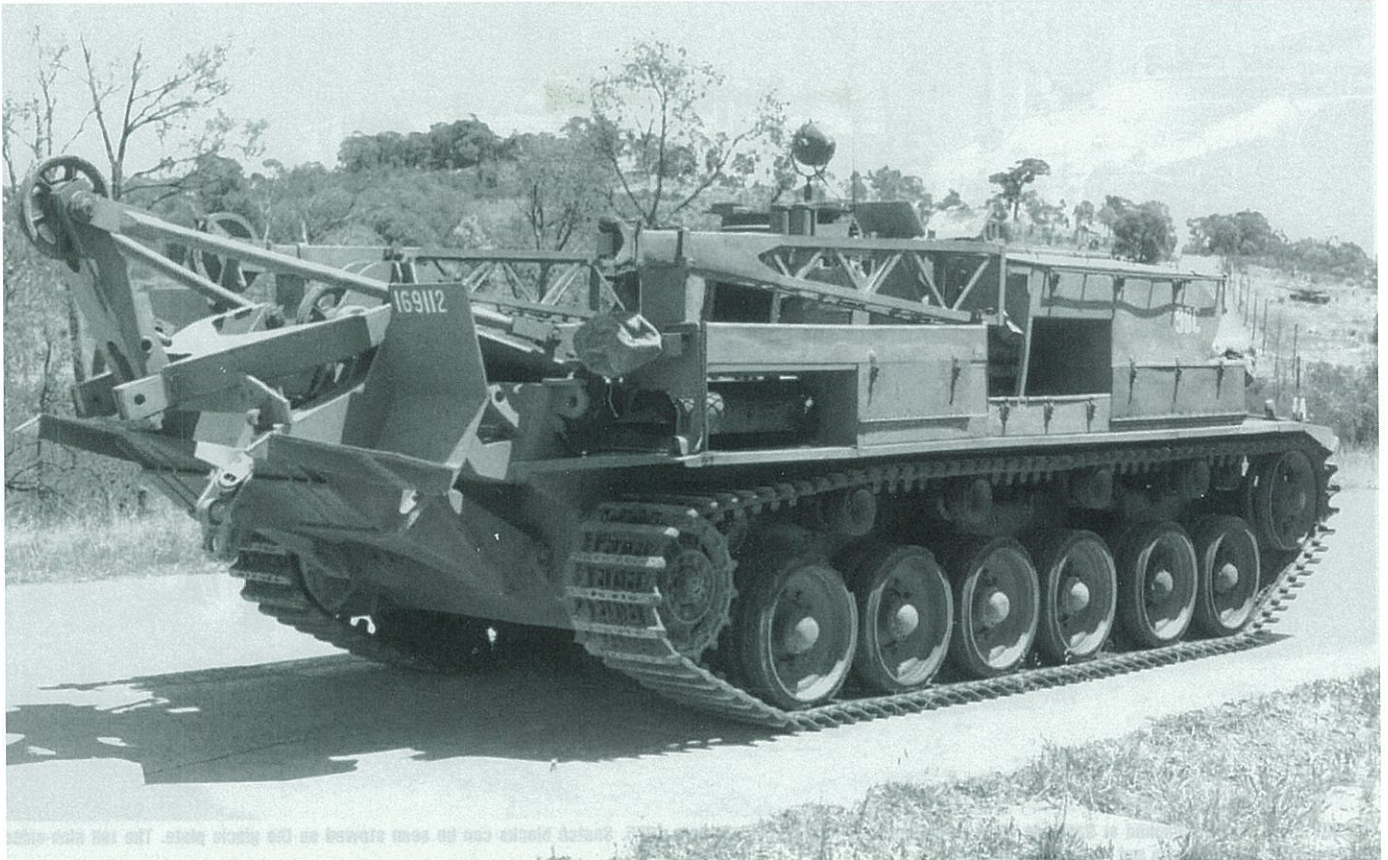

Fig 4 Layout of vehicle

An extract from the operator's manual, showing the general arrangement of the ARV Mark 2. The front lifting jib is shown in the working position. Although carried on the vehicles it was rarely used due to the time needed to assemble the jib and its inability to slew



A rear view of the ARV Mark 2 with anchor spade raised in the travelling position. The rear jib can be seen as can the two sections of the lattice jib carried on top of the stowage boxes

(APC) in support. The infantry and APC components were increased over the next two years. For some time there had been a push to support the Australian Task Force with tanks, and although the commitment of tanks was postulated as early as July 1967, an official announcement was not made until October 1967. Frantic preparations were made, but shipping space and non-availability of trained personnel meant that initially only a "half squadron" was deployed. The unit was designated C Squadron (C Sqn) 1st Armoured Regiment and the full Squadron equipment comprised two command/control tanks and two M577A1 Armoured Command Vehicles in squadron headquarters, four troops of four tanks each, a Special Equipment Troop of two dozer tanks and two bridgelayers, all supported by two ARVs. A Forward Delivery Troop with 3 tanks as "in theatre" replacement vehicles was also deployed.

C Squadron was accompanied by two Centurion ARV Mark 2 vehicles. The vehicles first deployed to South Vietnam were ARN 169112, carrying the radio callsign 38D and ARN 169122 which used callsign 38B.

Early operations in 1968 after the arrival of the tanks in South Vietnam led

to modifications being made by the workshops in theatre to improve the tanks' operational capability by lightening the maintenance load. The side bazooka plates were removed as well as the supports for them, as the vegetation was packing up between the hull and

plates and causing suspension damage. Although the bazooka plates fitted to the Centurion MBTs were removed after the first operations, they were still used on the ARVs until late April 1968.

Soon after the Centurion Squadron arrived in South Vietnam in early 1968,

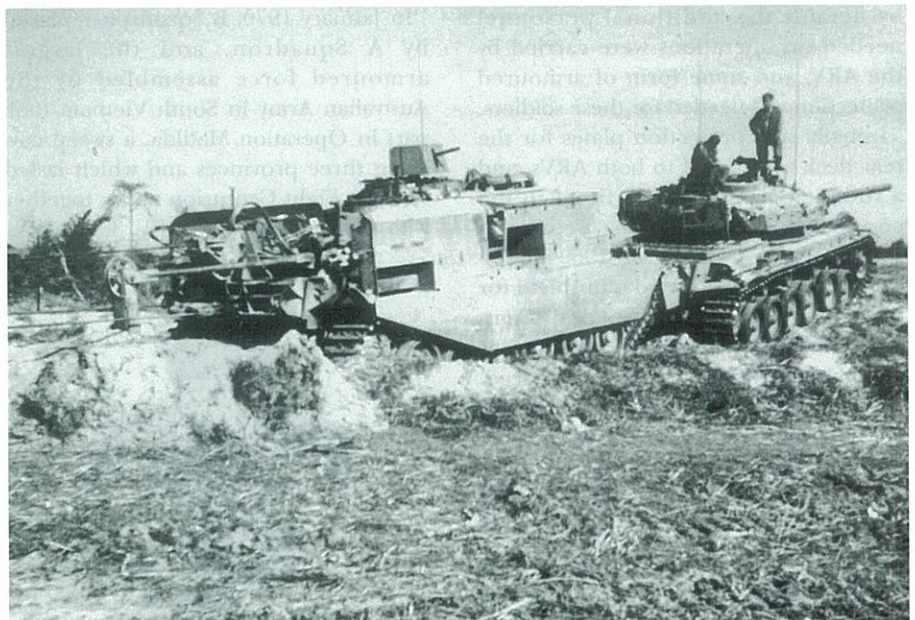

A Centurion ARV Mark 2 in South Vietnam during 1968. The anchor spade is embedded in the ground and the winch rope has been reeved into a 3 to 1 layout. A Centurion MBT has been hooked onto the front of the ARV to provide an additional anchor. The ARV has the rear deck protection plates fitted and a shield on the commander's machine gun



The ARV Mark 1 photographed at Bandiana after its withdrawal from service in late 1975. Snatch blocks can be seen stowed on the glacis plate. The tall slab-sided structure housed the winch and the Bedford engine

it became apparent that an armoured recovery vehicle would need to accompany tank troops on most operations. The nature of operations required that the tanks be accompanied by additional personnel, such as engineer mini teams, tracker dog teams, additional RAEME tradesmen, etc. Although the normal crew of a Centurion ARV Mk 2 was three – commander, driver and mechanic – by default the additional personnel needed on operations were carried by the ARV, and some form of armoured protection was needed for these soldiers.

Initially side protection plates for the rear deck were fitted to both ARVs, and a rudimentary shield was fitted to the commander's .30 inch Browning machine gun. Around early 1969 modifications for a wrap-around gun shield for the commander and a shield and gun mount for the operator to use another .30 inch machine gun were introduced. When 169112 was replaced in 1969 by 169113, the modifications were fitted to the new vehicle. It was considered by B Squadron 1st Armoured Regiment LAD such a necessity for these improvements to be fitted, that they produced a document detailing the work. It was hoped that vehicles could be so fitted in Australia before being sent to South Vietnam, and thus ease the workload of the already stretched frontline work-

shop. The Army did not want to have two standards for equipment and so did not act on the proposal.

As ARVs were commonly allocated to supporting single troops of tanks, they often came under fire, and they often found themselves accompanying the tanks during assaults and using their machine guns to provide additional fire support.

In January 1970, B Squadron replaced by A Squadron, and the largest armoured force assembled by the Australian Army in South Vietnam took part in Operation Matilda, a sweep covering three provinces and which lasted 11 days. Eight Centurion tanks, together with a bridgelay and ARV, 30 M113A1

APCs and some M548 Tracked Load Carriers borrowed from the US Army comprised the armoured component. In November, 1970 all available Australian AFV's congregated at Nui Dat to celebrate Cambrai Day. With 29 Centurions and 38 M113A1's assembled for the parade, it was the first time that the whole of Australia's armoured force in South Vietnam was assembled at the same time.

The Centurions were generally returned to Australia for rebuild after approximately 2500 miles in SVN, and 169112 was replaced by 169113 in the second part of 1969. It is thought that ARV 169111 replaced 169122 in late 1969.

196111 and 169113 remained in South Vietnam during 1969, and 169122 returned to South Vietnam in the latter part of 1970 to replace 169111. ARVs 169113 and 169122 remained on operational service in South Vietnam until the withdrawal of the tank squadron in September 1971.

The ARV Mark 2s were rebuilt along with the tanks, and all traces of the modifications made in South Vietnam removed. The vehicles soldiered on until 1976 when the first Leopard ARVs arrived late that year. The Centurions were retired in early 1977, returned to storage at Bandiana and later sold.



### Centurion ARV Mark 1

Although the design of a purpose-built ARV on the Centurion chassis began in 1951, the events in Korea where Centurions were first committed to combat with the British Army forced the introduction of a stop-gap machine. The Churchill ARV Mark 2 was introduced at the end of the Second World War and was just managing to support the new and heavier Centurion family. Some Centurion Tugs, tanks without their turrets, were used in Korea, but a winch-capable ARV on the Centurion chassis was needed urgently, and so the Royal Electrical and Mechanical Engineers' (REME) 13 Command Workshop at Aldershot set about the task.

Using existing Mark 1 and 2 Centurion hulls, a superstructure was built over the turret ring, inside which was a winch rated at 18 tons capacity. The winch could not utilize a power take-off from the main engine and was driven by a separate Bedford six cylinder petrol engine from the famous Bedford QL truck, which was still in front line service at the time with British units. An anchor spade was fitted at the rear, the design of which was based on the spade fitted to the Churchill ARV Mark 2. A cupola for the vehicle commander and a crew hatch were mounted in the roof, as were two hatches for accessing the winch and winch engine.

Production commenced at the 13 Command Workshop in 1951, and the vehicle was designated Centurion Armoured Recovery Vehicle Mark 1. The first eight vehicles were quickly despatched to Korea in 1952, where they were put to immediate use by the 5th Inniskilling Dragoon Guards REME Detachment and the supporting workshops. Further vehicles were built by REME Workshops until 1957, by which time 180 examples had been built.

### The Australian Centurion ARV Mark 1

During the late 1960s, the New Zealand Army decided to dispense with their Centurion tanks. In August 1968, the New Zealand Government advised the Australian Government that it was willing to transfer vehicles and spares of their Centurion fleet to Australia. As Australia was at that time heavily involved in South Vietnam the offer was given serious consideration. An Australian team visited New Zealand in October 1968 to inspect the vehicles, and it was decided to take the vehicles and a quantity of spares. The vehicles included one Armoured

Recovery Vehicle. The ARV was a Mark 1 model which was a different model to those already in use in Australia. Unlike the gun tanks, the ARV had been in undercover storage and was in running condition. It had covered 1492 track miles since being rebuilt and the winch had only completed an estimated 50 hours work. It was priced at \$NZ 2600.

Arrangements for the purchase were completed and the tanks were shipped to Melbourne by LSM, arriving in January 1969. With a critical shortage of Centurion ARV Mark 2s it was decided to issue the ARV Mark 1 to the Armoured Centre at Puckapunyal in order to free up an ARV Mark 2 for rotation to South Vietnam. Being an "orphan" did not matter so much in that case, and the ARV was pressed into service with the Armoured Centre Light Aid Detachment (LAD).

The ARV Mark 1 appears to have been built on a Centurion Mark 2 hull, originally given the War Department (WD) Number T 351718. It entered service with that wartime number converted to 03 ZR 66, and was allocated to the British Army of the Rhine (BAOR). It served in BAOR until January 1964 when it was sold to the New Zealand Government.

The Centurion ARV Mark 1 served at the Waiouru Camp with the Royal New Zealand Electrical and Mechanical Engineers in support of their 11 Centurion gun tanks. It was allocated the NZ Registration number NZ 31073.

When it entered Australian service, it was allocated ARN 169123.

Numerous problems existed during its Australian service, particularly with the anchor spade and the draw bar connection. The pitching between the ARV and a casualty when being towed, particularly during turning and reversing, caused bending and breaking of the pivot pin draw bar. Also, the connector for the draw bar had to be removed to allow the spade to be lowered. An investigation was carried out into the possible remedies, and two solutions were proposed – to replace the entire anchor spade assembly with that fitted to an ARV Mark 2 or to modify the existing spade and fit a Mark 2 towing attachment. As the Centurion fleet was nearing the end of its service life, nothing was done to modify the vehicle and the ARV Mark 1 was returned to 31 Supply Battalion at Bandiana in 1975.

### Preserved Centurion ARVs

The RAAC Memorial and Army Tank Museum is home to the Centurion ARV Mark 1, currently on long-term loan from Army Museum Bandiana, and to ARV Mark 2 169112, one of the first two ARVs deployed to South Vietnam in 1968. The Army Museum Bandiana holds another Centurion ARV Mark 2

#### Author

Major Paul Handel is a RAEME officer posted to Army History Unit as the Manager of the RAAC Memorial and Army Tank Museum, Puckapunyal.

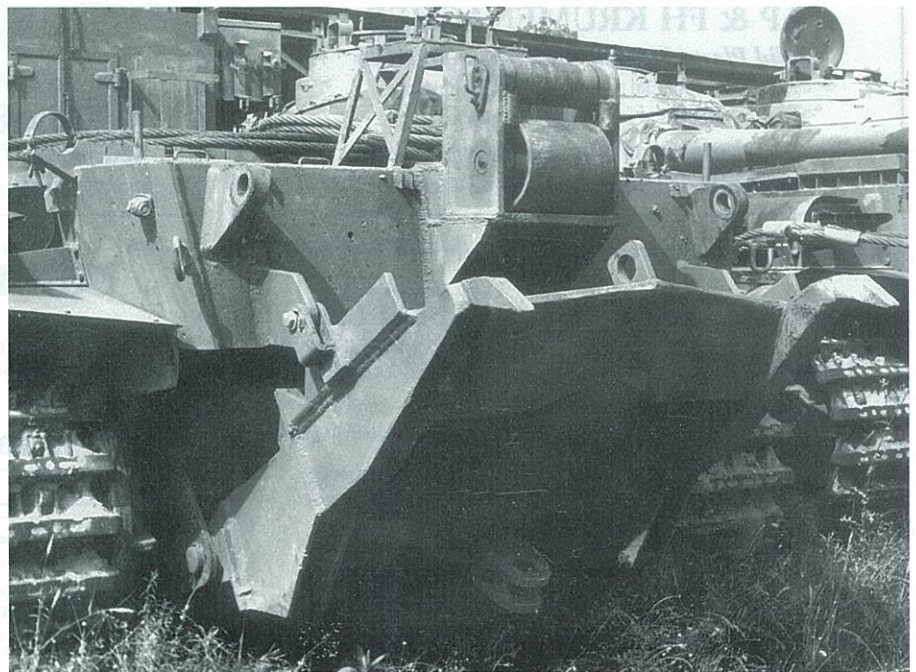

The rear anchor spade and fairlead assembly of the ARV Mark 1. The relatively light construction of the spade compared to that of the Mark 2 can be seen

## SKIP'S EVERGREEN

COMPLETE LAWN AND GARDEN CARE  
Yard clean ups • Rubbish removals • Gutter cleaning  
• Pruning • Lawn mowing • Small chainsaw work  
Fully insured • Commercial and Industrial  
**Contact Laurie – Mobile 0411 019 137**  
44 Peppertree Street, Kirwan  
ABN 11402016493

## SUPERIOR SCAPES

Landscaping Contractors  
• Commercial • Industrial • Domestic  
Defence Contracts Undertaken  
Enquiries to Magnus Moran  
**5529 4509 • 0412 732 709**

## CAPVAC

Industrial clean-up,  
roofgutters, ceilings, tanks,  
wet and dry vacuum service

Defence Projects  
Undertaken

Enquiries welcome to  
Allan James

Phone  
**0418 579 612**  
4939 1141

## Aussie Brush Strokes

- New Houses
- One Room
- Roofs
- Repaints
- Suede
- Industrial



FREE QUOTES

Call Peter on  
**Mob: 0408 874 705**  
**Ph: 4723 6215**  
**Fax: 4723 6165**  
16 Robert Town Cres.  
Condon 4815

## DODGE E PLANT HIRE

### SERVICING ALL AREAS

- Owner Operator
- Bob Cat (Skid Steer)
- 4 in 1 bucket
- Trencher
- Forks • Auger

Contact Chris

**Mobile 0427 703 120**  
**Phone 4778 8970**

Email: dodgeplanthire@aol.com

## DIAL A MOW

8927 2737

Servicing all areas of  
Darwin & Palmerston

- ★ Lawn mowing
- ★ Mulching
- ★ Edges trimmed
- ★ Rubbish removed
- ★ Clean-ups
- ★ Fertilising
- ★ Weed control

Contact Gavin  
**8927 2737**

**Mobile 0407 722 191**  
Fax 8927 3741

Email: dialamow@austarnet.com.au  
166 Vanderlin Drive, Wulagi

## L&S CONCRETE CONTRACTORS

\* Commercial \* Industrial \* Domestic  
Defence Projects Undertaken

Enquiries to Loui Galano

**0408 150 201 • A/H 3288 1974**

## GROUNDFORCE FENCING AND RETAINING WALLS

• Commercial • Industrial • Domestic  
Defence Projects Undertaken

Enquiries to Russ Eustace

**5428 6639 – 0410 508 951**

## GEseaco NATIONAL

Full range of container types for hire or sale  
• 2 pallet wide • Refrigerated containers • Cool rooms  
• 20' and 40' shipping containers • ISO tank containers

OFFICES NATIONWIDE

**Toll Free 1800 817 316**

Email: gld@geseaco.national.com  
Phone (07) 3276 8011 Fax (07) 3276 8033 Mobile 0401 991 657



## AP & FH KRUMENACHER

Solid Plastering and Rendering Specialists

• Commercial • Industrial • Domestic  
Defence projects undertaken

Enquiries to Tony Krumenacher

**3801 2198 • 0412 452 664**

## ARMA-TRIM

UPHOLSTERY – MOTORTRIMMING  
& CANVAS

- ★ HOUSEHOLD
- ★ AUTO
- ★ MARINE
- ★ QUALITY WORKMANSHIP
- ★ FRIENDLY/PROFESSIONAL SERVICE
- ★ FREE QUOTES



Contact Matt

**4775 6838**

**MOB 0412 772 475**

UNIT 4, 31 CASEY ST, AITKENVALE

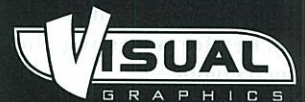

- general signwriting
- logo design • banners
- vehicle signage
- corflutes • digital imaging • posters

phone 4725 7777

fax 4725 4888

mobile 0417 719 636

email visgra@bigpond.com

## R & D COLEMAN

PLUMBER AND DRAINER

Maintenance, roofing,  
domestic, commercial  
and industrial

QBSA Lic. 68343

Contact Rod

Mobile  
**0418 779 140**

Fax 4788 7157

## LITTLE TRIMMER

Complete lawn care  
and yard maintenance

- \* Lawns mowed
- \* Edges trimmed

Contact Barry  
or Roslyn

Mobile

**0419 730 792**

Phone 4775 3695

## ACCESS INSULATION

QBSA No. 743951

• Commercial • Industrial • Domestic  
Major defence projects undertaken

ALL ENQUIRIES TO DAVID COMERFORD

**3255 9991 • Mobile 0407 571 813**

## N.Q. PACKAGING PLUS

Cleaning chemicals, detergents and disinfectants  
Mops, buckets, garbage bags, toilet tissue and hand towels  
Disposable food packaging, paper and plastic bags, cling wrap, alfoil

**4779 5299 • 4725 6431**

Fax: 4725 1463

Unit 3/30 Whitehouse Street, Garbutt

## WORKING SMARTER NOT HARDER

by LT Steve Mentshelyi, OC TSP 6 RAR

It seems common place these days that many Units or Organisations in the Department of Defence have to achieve more with less. Given posting priorities, manning shortfalls, tempo and the ever-present demands by Unit Commanders to get the job done. I don't wish to point out that my situation is any worse than that experienced by other units. I simply wish to praise the efforts of my Crafties and soldiers that put in an outstanding effort every day to achieve what needs to be done.

I am talking about the Technical Support Platoon at 6 RAR. The platoon has the equivalent manning to that of a Light Infantry SED workshop, 1/19. However the 6th Battalion currently holds a motorised SED compliment of vehicles that numbers about 207 veh types (including trailers) and the usual assortment of other Infantry Bn equipment. The liability certainly out matches the capability.

The platoons manning is not due to be increased until the introduction of Bushranger in mid 2005. Mid 2005 will see the reduction of veh types from 207 to 190 At which time the manning increases from 1/19 to approx 3/66. The crafties and soldiers do a magnificent job in meeting the demands of production and also meet the additional requirements of military training.

There are numerous reasons why little has been achieved to increase the manning in the interim and not through the lack of effort, the manning cap on 7 Bde's ARA positions and the shortage of trades across the army are but a few reasons.

At the end of the day we have managed to get by and keep everybody happy. This has only been achieved through considerable heartache and efforts by EME ops over the part two years. Namely the ASM, WO2 Bill O'meara and the past and present Platoon SGTs, Steve Araci and Glen (Junior) Mcfarlane. These blokes have done a magnificent job in juggling an ever changing list of priorities, and maintaining the momentum (Always important).

Our motto this year has been "work smarter not harder",

a small change from the previous motto "work hard play hard" as there has not been much of an opportunity to relax. I would like to know where the term "reduced work load" originated, as we have only experienced two modes "high tempo" and "even higher tempo". The Platoon has bounced from one exercise to the next with only sufficient time to re-equate ones self with SDSS and then pack the wagons for another foray to the field.

The Bn is full steam ahead in preparation for a nine-month deployment to Timor as the last rotation prior to the withdrawal of the UN. Over this deployment I am happy that nearly 80 per cent of the Platoon will deploy over the course of nine months. A reward that has been a long time coming for many personnel.

My Crafties and soldiers have moved mountains in the last two years. They have done a magnificent job that is far over due for noteworthy praise. To all the Crafties and soldiers of Technical Support Platoon that are still with the platoon or have moved on over the last two years I thank you for a job well done.

## JLU-N

### The fleets...

It has been another busy year for all three fleets, Mobility headed up by SGT Dave Bernat, Tech Marine by WO2 Gordon Watkin and Comms Elec by SGT Andrew Harvey. Keeping the whole rockshow humming is WO1 Paul Dodge and the Boss, Captain Trevor price.

The structure has been changed to accommodate the inevitable DIDS contract which has mainly involved the removal as much staff as possible without removing the workloads associated. That coupled with SDSS version four rollout and TRF and other quality audits looks after any other "spare time". There has been still time for the occasional beer and sporting event keeping the RAEME spirit alive so its not all doom and gloom.

There is a big change over of fleet staff next posting cycle with SGT's Bernat and Harvey being posted out of their comfort zones. It will be an even more challenging year next year with the roll out of DIDS so "good luck" to the incumbents!

## HILLMAN MOTORS

PTY LTD

**MECHANICAL ENGINEERS**

- Fitting & Turning
- Machining
- Engine Overhauling
- Diesel Pump & Injector Overhauling

*For anything God put fuel into*

Large range of spare parts  
Defence Enquiries Welcome

**Ph: (07) 4927 2355**

ROCKHAMPTON

## SCARLETT CONSULTING Pty Ltd

33 Blue Hills Drive, Toowoomba, Qld 4350

*Electrical Engineering for Building Services, and associated site works*

- ★ Power Reticulation ★ Standby Generation ★ Fire Alarm Systems
- ★ Lighting Systems ★ Telecommunications ★ Security Systems

**ALL DEFENCE ENQUIRIES WELCOME**

**Phone: (07) 4636 2500 Fax: (07) 4636 2533**

Email: tonyscpl@bigpond.net.au

*Proud to be associated with the Australian Army*

## Honeywell Normalair-Garrett Australia

OPERATING DIVISIONS:

Manufacturing, Product Support and Turbocharger

Head Office: 45 King Street, Airport West, Victoria 3042

Ph: (03) 9267 9300 Fax: (03) 9338 8282

www.normalair-garrett.com.au

## GET YOUR CARPETS PROFESSIONALLY STEAM CLEANED

*by Cleana Carpets*

*At some of the CHEAPEST  
prices in Townsville*

**100% SATISFACTION  
GUARANTEED**

*Receive a FREE stain removal guide*

*Also Cleaning of Vertical Venetian Blinds*

Contact Phil or Sophie

**4789 2873**

CLEAN TEAM

Email: cleana@ozemail.com.au

**WORKSHOP FOLLY'S**

The new year began with the promise of a take over merger by the civilian contractor for DIDS, but strangely enough it didn't happen on time and were all still here.

On a regular basis we have LT COL "Beans" Bevans and Major Steele our unit boss's floating through the workshop to ensuring that various pieces of equipment meet their operating capabilities.

Positions have moved around with the New Year with WO2 Gordon Watkin (travelled all the way from England to come to Darwin. HeHeHeHe) and SGT Dirty Dave Bernat (mongrels of to 51 in Cairns) now cracking the whip over the trade repair officers. These fellas make sure the Defence dollar is spent well in the Darwin area.

Down on the floor we have CPL Jones (leaving the defence on a final promotion to mister) slaving away and running the workshop with an iron fist, but only on those occasions that he can be found.

We have CFN Sonia Lyons as our new greaser and she has spent countless hours helping Mr John Ilko our civilian greaser bring our vehicles up to speed. She has been a welcome new addition as she has bought new ideas and methods of repair to the workshop

On the topic of Crafties and things that go bang in the dark, CFN Tanya Mastroieni, our new fitter has been keeping all our guns in nice straight lines in the Armoury. She has also put the rest of us to shame with the amount of push-ups she pumps out in one day.

Our latest addition has been Mr Mick Downs who claims to work on our fridges and other things that produce spark and smoke when adjusted by fitters.

Finally it can only be sadly said that with DIDS on the doorstep JLU-N is staring down the barrel of a rusty Styer.

With that I wish all the members of the workshop a sad good-bye and farewell.

**The story behind "the Pom"**

I First heard that it was possible to join the Australian army whilst I was serving as an Equipment Care Inspection (ECI) is the MAS equivalent) Team leader in 160 (Welsh) Brigade, Brecon, Powys. From the initial application to SCMA it was 15 months to my swearing the oath in the Australian Embassy in London and Flying to Darwin the same evening with my wife and four children.

Due to the SARS virus we flew via America, which took 32 hours flying time, which was quite tiring but it was great to arrive in Darwin to be greeted by Captain Price RAEME (my OC) and to stay in the Saville Hotel overlooking a Tropical sunset.

I have now been in JLU (N) for 4 months. I am being employed as a Regional repair manager for the Marine/General Technical Fleet, which with a background, as a Vehicle Artificer has been a steep learning curve. Jason Moon and Merv Ransome (the two CRS in the section) are looking

after me and instructing me in the "Australian way" which has included strippers and beer!

I have already made new friends and had a great time so far. I'm looking forward to the new challenges Australia will bring for me and my family and hope that we will all make a go of it here.

**A Boffin's view...**

Welcome to the hard working EIR section of JLU-N, where the men are men and the Oi's are rampant. My self, CFN Dan Leatham and CFN Brendan "BJ" Tunnie have been posted in, filling the TES positions of CPL Michelle DeFriskbom now posted to JLU-SQ along with her other half Mr Todd DeFriskbom and LCPL Tony "Timmy" Hill posted to 1st Armoured as a CPL. Also Posted out radio mech CFN Adrian Graham to 8/12 Medium Regiment. SGT Andrew "Harves" Harvey has stayed on after the promotion of the then WO2 ART ELEC Wayne Male into the "vacant" CRS position (who wrote the selection criteria??) for another year. Mr Michael "Dixie" Dicks is still with the unit doing all the tels work along with whatever else he does behind his locked door.

As for the production in our section BJ and I have had plenty of Ninox and TESS to inspect and repair as well as the usual binos and compasses, and there's not a day goes by when the engraver isn't operating. Also throughout the year we have had a couple of FRT's away with Norforce inspecting all their equipment and playing up while away from home in Broom and Alice Springs. Dixie has continued to fix radio stuff, and recently, JLU-N has been given the nod to fix Wagtails for the northern region where previously they were sent to DNSDC.

Sports wise for the section, a recent challenge put forth by 161 Rec SQN to a game of cricket showed to be a win for JLU-N with Harves topping the runs for the team and Dixie 3rd for the run count retiring due to being stuff from running to much. Good work EIR and the rest of the team.

**VEHICLE TECHNOLOGY WING – THE YEAR IN REVIEW**

The new year presented VTW with quite a turn around in manning as the initial shouts of, (not 'production! ... production! ... production!'), 'instructor loads' and 'net training liabilities' rung out across the wing. MAJ Chris Willmann departed to head up to the Vegas so it was up to MAJ John Haley to take over the reins of the wing from his position as the boss of the EME cell at Integrated Logistics Division – The Home of Military Logistics. With last year's 2IC, LT Scott Dove, off to greener pastures at 4 Fd Regt (chuckle), the incoming RAAFie, FLTLT Rosemary Dyke, was considered to be a fair swap

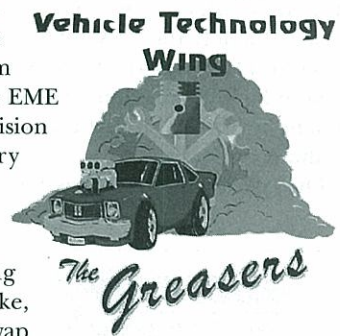

RAEME CRAFTSMAN Summer 2003/4

**TOWNSVILLE GRADED SANDS**

- SAND ● SOIL ● GRAVEL
- SLAB FILL ● FEATURE PEBBLES
- QUARRY PRODUCTS

**4789 0477**  
**Mobile: 0411 658 843**

Ross River Rd, Dam Site, Upper Ross River Rd, Kelso  
 Email: [townsville\\_graded.sands@bigpond.com](mailto:townsville_graded.sands@bigpond.com)  
 Web: [www.paradisepebbles.com](http://www.paradisepebbles.com)

**LORNA INTERIORS**

- CUSTOMIZED CURTAINS
- COLOUR SCHEMES
- SHUTTERS & BLINDS
- MOTORIZED TRACKS
- INSTALLATIONS
- COMMERCIAL & DOMESTIC

**LORNA CORGAT**

Phone: **0419 189 669**  
 Fax: **4775 4304**  
 PO BOX 5943  
 TOWNSVILLE QLD 4810  
 e-mail: [lornacy@bigpond.com](mailto:lornacy@bigpond.com)

**MENDI CONSTRUCTIONS**

*Civil Construction Contractors*  
 Commercial and Industrial  
 Defence contracts undertaken

**Enquiries ph Jeff Doyle**  
**Ph: 4774 4175**  
 Fax: 4774 4179  
 BOHLE



Anyone for a dip?

by all of those who knew Dovey. In all seriousness though, Rosemary is coming to grips with the 'green' way of doing things and appears to be enjoying herself working with the Army. Other new comers to the Initial Trade Training Group (ITTG) have included LT Andrew 'when I was a

public servant' Mahoney, LT Craig 'what are you wascally wabbits waffing at' Poyser, SGT Peter 'we didn't do it that way in the 'Ghan' Solomon, SGT Brett 'check out the size of my lunchbox' Williams and SGT Robert 'I was the BQ' Turnbull just to name a few.

Under the ever watchful eye of the Group Commander, WO2 Peter Beaton, the ITTG sausage machine has managed to churn out 108 graduates (including 36 RAAF GSE Fitters) this calender year to send off for twelve months OJT in one of the more desirable locations around the country. In addition, the boys up at Careers and SETG have been busy pumping through promotion and specialist courses.

Fortunately for the trainees, there has been a definite swing back towards producing 'soldier tradesman', a change sure to be welcomed by all who regret the loss of the apprentice system and the 13 week recruit course. Effectively, VTW in conjunction with Mil Skills platoon, provide the lads with a further 25 days of military training in an attempt to cover the training gap left by the current system. From the wing's perspective, Battle PT has been re-established into the timetable, or out of the timetable as it starts at 0620 so as not to cut into the civilian contractor's teaching time and cost the unit a gazillion dollars for lost productivity. Military training also takes place on every other

Wednesday afternoon in order to prepare the lads for the culmination of the years training: Exercise BROAD HORIZONS.

Exercise BROAD HORIZONS was not designed to be IMT's, but to provide trainees with an insight on what life in the field with



CPL Plumridge tell me again how it works?

combat service support units will be like. It revolved specifically around deployment of CSST's, occupation and daily routine in support of our combat arms brethren. After a short walk into the position the boys were given a heads up on operating with a CSSB: digging holes. A task which most relished but some loved, particularly CFN Paul Purchase, who would not let anyone come between him and his trusty mattock. Poor Paul has wanted to go and kick doors and choke chooks since he first arrived so hopefully during his posting to Sydney he will lose the urge for such things.

Once the exercise got into full swing, night routine which involved standing patrols, ambushing and navigation, was balanced by an array of presentations during the day including occupation of a new site, survival, cam and concealment etc etc. The WSM, WO2 Tibor Fekete, certainly approached his subject with a positive gusto well known to the lads, and he whipped the boys into veritable frenzy of enthusiasm.

The culmination of the ex was a mil skills competition called Exercise Trained Soldier (ETS). The ETS was designed to test the application of skills learnt during the exercise and included the usual navigation and first aid stands and also the more enjoyable jerry can carry and trailer push. The lads approached every activity with enthusiasm and put in throughout the day. Unfortunately, they tended to go like a bull at a gate instead of thinking of the easy way out as do lazy people like the boffins. This resulted in some average final scores, but the enthusiasm and zeal shown by the VTW boys was not matched by either the boffins or fitters.



Which way up?

Congratulations must go to CPL Peter Cooper's section, who topped the VTW results and subsequently won back the title of Champion Platoon for 2 PL.

The year on the sporting field has seen VTW reign supreme and leave the miserable fitter and boffin types in



MAJ Haley presents the Champion PL trophy

Proud to support Australia's Armed Forces

## Ebsray Pumps Pty Ltd

Specialist supplier of custom built \* Petroleum \* Fire \* Water pumps sets to the ADF

628 Pittwater Road Brookvale NSW

Ph: (02) 9905 0234  
Fax: (02) 9938 3825  
www.ebsraypumps.com.au

## PROFESSIONAL BRICKLAYING Pty Ltd

Commercial and Industrial Bricklaying Specialists

### MAJOR DEFENCE PROJECTS UNDERTAKEN

Enquiries to Scott Presnell  
3841 2543 or 0411 558 388

Winner of 2002 Business Achiever Awards

• Defence Enquiries Welcome • All General & Mechanical Repairs •

### ALL WORK GUARANTEED

Phone Jason Garlepp on 4922 5956

## FK GARDNER

AND SONS PROPRIETARY LIMITED

### COMMITTED TO QUALITY

BUILDING & CIVIL ENGINEERING CONTRACTORS  
MAJOR CONTRACTORS FOR COMMERCIAL, INDUSTRIAL & INSTITUTIONAL BUILDINGS  
PRECAST CONCRETE CONSTRUCTION (TILT UP)  
DESIGN & CONSTRUCT PROJECTS  
PROJECT MANAGEMENT  
REGISTERED BUILDERS NO. 20511

Cnr Straun & Carroll Sts, Toowoomba

## PH: 4633 6200

our wake. The victories started with the swimming carnival and have also included the touch football, cross-country and the tug-o-war. Special mention must go the VTW heavy weight side after their victory against the fitters and chippies. Outweighed by nearly 100kg by the pie-eating experts at Armaments and Construction Wing (ACW), the greasers came back from a 2-1 defeat in the heats to take out the heavyweight final 2-0. The carrot eaters also performed admirably going through the whole day undefeated, again demonstrating total greaser dominance over the other trades. As a result, VTW looks certain to extend its stranglehold over the Champion Wing trophy for yet another year, as we have a near insurmountable position on top of the ladder with only two competitions remaining.

So as another training year draws to a conclusion, the results speak for themselves. Our mandate of producing 'Soldier-Tradesmen' for Land Command remains the focus of our endeavours. This task has proven to be all the easier due to the high quality of staff predominantly being of the caring, understanding, nurturing type. The training they have provided and the fact that winning every competition tends to support the claim that Vehicle Technology Wing is not only 'Champion Wing', but a 'Wing of Champions'.

*Arte et Marte*

### 8/12 Mdm Regt

*By Cfn's Carlin and Gardiner*

Welcome back for another round of goss from the F\*A\*R\*T. To meet deadlines the lads were working super long overtime, upstairs ensuring we attended every parade and function, writing off whole days every week. Cfn Carlin decided not to contribute at all by dropping a machete on his foot and scored 6 weeks at home, but held the fort with Cfn Gardiner by doing guards every 3rd day while the lads went to the worlds finest training area for a well earned holiday.

Did I say holiday? The team demonstrated great patience with our fine Mack gun tractors (possibly the most flogged vehicles ever), and their constant breakdowns. Fieldy and Gordo killed their Mog on the road trip when the diff felt its oil was better off in the torque tube. The truckies running gunnies over added a little entertainment, as did the home gym, bread-maker and pro-logic home entertainment system with DVD library. The rear ech also played enemy to the brigade for a bit, much to Lt Jackson's delight, and it took all of about 2 minutes for 2 Cav to roll through and wipe us out until they ran out of ammo.

There was a fair bit of carrier panel beating as usual, and plenty of minor repairs. Cfn Limbach was extremely busy turning the genny on and off. Sgt Stephenson locked his toolbox

and used everyone else's tools, and had his GMV set up as the Winnebago campervan with more food and cooking utensils than tools and parts. The Ace spent his days keeping it real with the boys, unlike Lt Jackson who turned GE into a sweatshop for backyard carrier mods.

Our new OC Capt Telleria runs the show now, and keeps us amused with warries like 'one time, in reserves...'. Lt Jackson has more time now for his engineering projects and we even see him on the floor sometimes when it's not too hot. And we still have our dear old Ace, W02 Nugent, though it appears he'll be leaving at the end of the year for Melbourne.

Vehicle section has been super busy, especially after the flogging we copped off MAS. Lcpl Barker is still running the service bay with our two civvies, and a team of truckies to do the dirty work. Cfn Paterson is our resident carrier king, gaining the position immediately after marching in and doing his maintenance course. Cfn's Carlin, Gardiner and Wright have held the floor under Cpl White. Cpl's Herron and Bosworth are still 103 and 101 Bty's vehicle Cpl's and Sgt Stephenson is running the show from in and outside the office, watching our every move.

GE's been flat out too due to jobs like our infamous heave beams. Cfn Manefield, when not plumbing guns, has again been making better tools than Snap-On for us, like filter-eating wrenches, tube spanners for hub nuts and a million others that warrant patenting. Cpl Weber, Cfn Wighton and Sgt Maher have been busy in the armoury and doing various other engineering jobs for Lt Jackson. Sgt Chiverton went straight to 103 Bty's tiffy position, the envy of no-one, and Sgt Smith is in the same boat in 101 Bty having most of the guns in pieces for crack tests.

EIR has lost its favourite bad-boy Cfn Graham to civvy street,

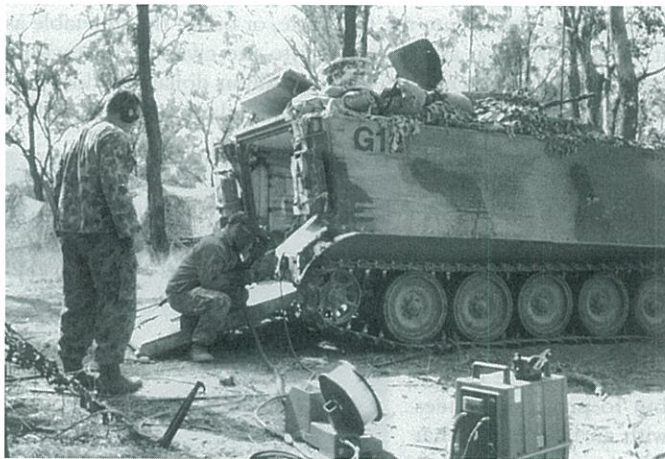

Cfn Manefield and Cfn Wighton customising an APC

## Tropical Water Solutions

Water Quality Consultants

Specialising in  
Chemistry  
Biology  
Applied Science

www.tropicalwater.com.au

Ph: (08) 8947 3676

## Rezitech Services Pty Ltd

VACUUM PUMP PARTS & SERVICE

Repairs to all Fluid Flow Equipment  
Belzona Distributors Australia

Contact Michael on Mobile: 0405 183 492

Phone: (07) 4774 6077 Fax: (07) 4774 6611

7 Camuglia Street, Garbutt E-mail: townsville@rezitech.com.au

## RIVER CITY CONCRETE PUMPING

■ COMMERCIAL ■ INDUSTRIAL ■ DOMESTIC ■

Concrete Pumping Specialists

MAJOR DEFENCE PROJECTS UNDERTAKEN

Enquiries to Vicki Petersen 3890 0635  
or Mick Petersen 0402 231 439



100%  
Australian Owned  
Defence Force Suppliers

- White Milk Products
- Dare & Oak Flavoured Milk
- Creams & Custards
- Macquarie Valley Juice & Water
- Ski Yoghurt
- Coon Cheese

PH: 4727 5942  
62 Bolam St, Garbutt



8/12 TST in convoy at SWBTA

and although the workload isn't huge in there, the place won't be the same. Ever get a filthy power-point e-mail? Odds are he made it. Cfn Phillips has had a busy year, with more courses than the PGA tour, then straight to bush from sub 1. And hero to all up and coming boffins Cpl Gordon has also been keeping it real in the freezer that is EIR, performing upgrades on flashlights and generally maintaining a low profile. Elec has also had it quiet with Cfn Limbach spending more time doing work for the greasers than anything else.

We lost our recy mech crafty Stoney to 2 Cav at the end of last year, causing Cpl Frank Keitaanpaa to almost have to justify his pay rise. Not the case at all, Frank is still doing more skiving than a hydraulic hose maker, only rising from his desk for another brew.

The rumour mill has also had a workout, producing the following items of speculation and intrigue. Though not all true, most are fitting and should at least raise a few eyebrows ...

**Patto** – Stopped whining for 5 minutes and was rushed to hospital.

**Dave** – His blood samples from a post-Butterworth test have been returned, stamped 'unknown'.

**Fieldy** – Took over GE to start his own business - 'Fieldy-Built Tool Company'.

**Will** – Has been at work, however hasn't made it past the smoking area out the back.

**Scotty** – In the process of colouring his whole body in with ink. Also lifts Rover engines out for us when the crane's busy.

**Luke** – Currently revising his Kingswood's owner's general knowledge for the NT finals coming up soon.

**Grant** – Woke up briefly during last week, but was soon back to sleep.

**Mick** – Also woke up last week, but grabbed a beer before racking out again.

**Adrian** – Now a civvy, did attend work when rugby training wasn't on. Will be sorely missed by the brew fridge.

**Brodie** – Seen doing non-dodgy work, sparking an investigation and is under review. Leaving us for SASR.

**Boz** – Transferring to the RAAF to be 'Top Gun' mechanic.

**Big Sean** – Undertaking a vigorous weights program on his legs so they match his top half, and also leaving us for SASR.

**Whitey** – Off to 1 CSSB after hitting his head while walking under his desk.

**Frank** – Also leaving us for 1 CSSB, freeing up much needed oxygen.

**Timmy** – Is guarding his flash-as Chev with a shotgun after us crafties learnt to hotwire it.

**Gordo** – Has built a robot to take his place and currently building more to take ours too.

**Stevo** – Flaunting his beloved pink shorts at any inter-unit sporting event he can attend.

**Dennis** – Taking sexual innuendo to a new level whilst driving along Dick Ward Drive to Fannie Bay.

**JJ** – Rumours of similarity to The Hulk were confirmed when his post mid-year function skin colour was pale green. Will be corrupting young fitters at ALTC next year.

**Chivo** – Mysterious quiet achiever. Rates as the coolest senior because of his sideburns.

**The Ace** – Is having Lt Jackson engineer wheelchair access for his Torana.

**Lt Jackson** – Cried and went home when NSW whipped QLD at the first round of state of origin.

**Capt Telleria** – Working on his heavens and will soon be able to do one.

And the RPS lads didn't miss out, with ...

**Rooksy** – Parts guru extraordinaire, this madman command rear details with an iron fist and a pointy boot.

**Corcs** – Who? Unseen since Malaysian swan trip, apparently he has something to do with tools, but this remains to be seen.

**Hanno** – 'Pauline' to the boys, is noted for sculling green chartreuse. Rated this years Raspberry Creek dance as the best yet.

**Barra** – the gentleman of the parts store, doesn't hesitate getting you what you want. Speaks fluent greaser and fitter, will be learning boffin later this year.

**Big Brad** – RPS's muscle, can kick a 20L drum of coolant over the workshop roof.

And that's us. 'Til next time, *arte et marte*.

### 3-02/03 SUBJECT 4 SGT (MECHANICAL) COURSE

Written by CPL S. Maher. 24 Jun 03

As everyone who has done a course at Army Logistic Training Centre (ALTC) knows, it isn't complete until a course plaque is presented to the wing staff. The plaques usually represent an event or common theme from the course. Just about every wall in the Vehicle Technology Wing (VTW) is covered in a wide variety of plaques, ranging from the extremely funny, slightly non-compliant with today's equity laws (which are always covered with curtains), to showing the hatred felt by all towards computers. The challenge is to try and stand out, compared to the rest.

Over the period 28 Apr – 20 Jun 03, the latest 'pilot' Subject 4 SGT (Mechanical) course was conducted at VTW ALTC. The course consisted of 15 mechanics and Fitters, including three G-Res tradies.



Course members – Rear row L-R: Cameron Roach, Aaron Moseley, Ian Lippiatt, Shaun (SOM) Smith, Peter Cox, Nick Nolte, Paul Burdin, Toney Kulboer, Scott Hill, Michael Garnham, Steve Leyden  
Front row L-R: Tim Smith, Andrew Lebsanft, Sacha Pawlowski, Steve Maher  
Staff: Wo2 Angus, Sgt Wallace, Sgt Pederick



Construction Team: CPL Steve Maher, CPL Nick Nolte, CPL Aaron Moseley

A good time was had by all, however there were some difficult sections of the course, especially in the maths and report writing areas. An excellent trade trip to Melbourne was the highlight for most, with visits to several major industries including, Caterpillar, Kenworth, Toyota and Cummins. A 20-25 minute presentation on aspects of the trade trip completed the course with some people showing their hidden talents.

In keeping with tradition, a plaque was required to show future courses how we survived the eight weeks. Normally it can

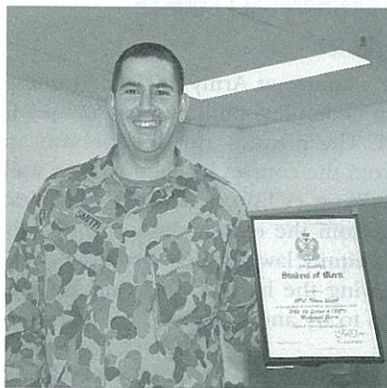

CPL Shaun Smith (SOM)

take a few weeks to think of a common theme, not this time. The first night at the boozier was the usual, catching up with mates you haven't seen for many years and sharing a few beers with a few good stories. At the end of the first night, we noticed we had quite a decent pile of empties.

The next day the idea was thrown up to build something out of beer cans. With a bit of fine tuning, a bar was planned with 'RAEME pride' to be the main theme. The beers to be drunk were chosen, Melbourne Bitter, XXXX Gold and Tooheys New, and we were off.

Once there were enough colour-coded cans for the front and sides, everyone continued to drink their preferred drop, to ensure all had a part in the bar. We must have looked like a bunch of scabby bag-ladies, collecting all our empties in garbage bags at the end of every night and humping them back to the lines. With a quick wash, the cans were stored in the lines till the production team; (Nick Nolte, Steve Maher and Aaron Moseley) had enough liquid nails to build another section. Some



Front foyer of VEH

building sessions didn't end till three am.

Very big thanks goes out to CPL Stephen Corkery, C & J Instructor at ALTC, for doing all the timber work and mounting the taps and course photo. An excellent job that finishes the bar with class.



Construction

A thanks also goes to Wyong RSL for providing the taps, courtesy of CPL Leyden, (who happens to be their president). Also the cleaning ladies for not damaging the bar sections while they were spread all over our common room. Reprographics also gets special thanks for providing the gold lettering for the course title as well as the course photo.

**Statistics:** 19 cans wide

9 rows high

6 rows deep

1026 beer cans total

8 tubes of liquid nails

Estimated cost incl timber work etc, \$3000 plus.

Estimated value: PRICELESS!!!

Next time you are down on course, or just driving by, take the time to check it out, the photos can only go so far to show its class.

We have doubts, but let's see if anyone can top this one!!



Moving to Chippie Wing

### NORFORCE Tech Support Troop

It's been a busy year for all at NORFORCE TST. We started off the year with a few new faces to replace those that had left. CFN Brendan Axford left to the promised land of the RAAF, CFN Andrew Fraser converted to part time after enjoying some long service, whilst CFN Mick Austin took 12 months off to help with his family's business. These guys were replaced by CFN Alfie Putinja from 10 FSB, CFN Ian Bradford from 36 Water Transport and CFN Scott Hiller from 7 CSSB. Left over from last year we have:

**Full Time:**

SGT Michael Robinson – Workshop supervisor

CPL Malcolm Goldner – Veh section

CPL Jason McLinden – GE/Marine section

CPL Mick Castilla (token roach!)

CPL Adam Read – Radio Mech

CFN James Worley – Veh section



CFN Bradford (front right) with his farewell gift

#### Part Time:

WO2 Wayne Detering - ASM  
SGT Frank Mcdonell - Veh section  
CPL Warren Bryce - Veh section  
CPL Justin Hanson - Veh section  
CFN Dave Wedmore - GE/Marine  
CFN Luke Kain - Veh section

With an AO stretching from Darwin to South Australia, and Broome, WA, to Nhulunbuy, NT, we get to see a fair bit of the countryside, with at least two trips per year to each of our remote squadrons. A few extra trips are always on the cards, including a two week community engagement exercise/ 'fishing expedition' to Ngukurr and Numbulwar, and numerous FRTs.

Back in Darwin we are kept busy with the usual work and kept on our toes by the implementation of the TRF along with the new 'user friendly' version of MIMs/SSDS.

As the year nears it's end, a few old faces are departing with CPL McLinden off to 4 RAR, SGT Robinson going to 1 CER, CPL Goldner maybe to 1 CER and CFN Worley to a destination yet to be confirmed.

Last but not least, CFN Ian Bradford has decided to go on to greener pastures after 15 years of undetected crime; we wish Ian and his family all the best in the years ahead.

*Arte et Marte*

## Army logistic Training Centre, Integrated Logistics Division

### Maintenance Cell

2003 was another successful year of educating members of the Corps in the doctrinal way of conducting business within RAEME. To do this the cell conducts a number of courses throughout the year. The courses conducted include:

- Subject Two CPL, 10 per year;
- Subject Two SGT, 5 per year;



Back row: SGT Morrison, SGT Wosgien, SGT Jones, SGT Bellette, WO2 Luck, WO2 Henry, SGT Vandermeer. Front: WO2 Beattie, MAJ Nasir, MAJ Warne, CAPT Tinning, WO1 Luke, (WO2 S Irwin) WO2 Frost

Special to Corps training WOLOG, 2 per year;  
Special to Corps training LOBC, 2 per year; and  
Special to Corps training LOIC, 2 per year.

This start of 2003, saw the posting of two aviation tradesmen and two recovery mechanics into the cell. Warrant Officer Class Two Chris Beattie and SGT Paul Vandermeer were the lucky two aviation tradesmen chosen, along with our resident recovery mechanics of Warrant Officer Class Two Paul Luck and SGT Terry Jones to fill the positions within the cell. These members have brought with them a wealth of knowledge and professionalism that has enhanced the way that the cell conducts and delivers training.

The members currently posted to the Maintenance Cell are:

CAPT Jock Tinning – OIC,  
WO1 Steve Luke,  
WO2 Chris Beattie,  
WO2 Steve Frost,  
WO2 Chook Henry,  
WO2 Paul Luck,  
SGT Nigel Bellette,  
SGT Riki Morrison,  
SGT Terry Jones,  
SGT Steve Wosgien,  
SGT Paul Vandermeer.

Malaysian exchange officer – MAJ Nasir

Overseeing the Cells operation and trying to rein in and control it is MAJ Simon Warne as the Senior Instructor Integrated Cell Two.

Other RAEME members within ILD are:

CAPT Scott Barras, and  
CAPT Scott Jenkinson

The cell, has recently moved from the top floor of the Integrated Logistics Division (ILD) building and relocated across the road giving us more space to conduct our training and allowing the cell to demonstrate to the other Corps what 'Corps Pride' is all about. Thus causing the cry of 'bloody spanners' to be heard echoing around the corridors of the ILD building.

This year saw a number of 'firsts' happen within the cell. The Maintenance Cell took on the responsibility of delivering the Sub 2 CPL RAEME course. To enable our training liability of 10 courses per year to be met, with each course having 20 Students per course consisting of 18 positions for ARA and 2 for GRES, five RAEME SGT positions were established, specifically for this course. As this was the first time in about 11 years that this course was conducted in the Albury Wodonga Area, a large amount of development work was required especially in the amendment and alignment of the TMP, currently designed around the Ground RAEME, to accommodate the aviation trades who attend the course, prior to the pilot course commencing in April. The content of the course covers RAEME in the JFAO, SDSS/MIMS, Corps History & Ethos, five days out field for the FRT phase, RAEME documentation and compiling and delivering FRT orders.

Earlier in the year, WO2 Paul Luck and SGT Nigel Bellette travelled to Darwin to assist with the running of a Subject Two (CPL) RAEME course conducted by 2nd Cavalry Regiment. The lessons learnt by these two members were used to assist in the development of the Subject Two (CPL) RAEME pilot course that was conducted by the Maintenance Cell in April.

The pilot course went off without too many concerns, thanks largely to the development work conducted by the SGTs. However, with the feedback provided by the students, the course and TMP has continued to be refined.

The Logistic Officer Basic course has also had a number of changes this year. The main one being the introduction of the field phase that saw all students and some DS spend 10 nights in the Mount Stanley State Forest in what can only be describe as freezing conditions. This sees the young (and not so Young) up and coming officers gain an understanding of DP's and deployments. With the other changes seeing the cell, deliver the same lessons at different time for the same course (a bit like ground hog day).

With the year quickly coming to a close a number of members are looking forward to being posted to greener pastures:

CAPT Jock Tinning – Long Term Schooling,

WO2 Steve Frost – PNG,

WO2 Chook Henry – Doctrine Cell ALTC Bandiana, (CAPT 2004)

SGT Nigel Bellette – WSM VTW Latchford Barracks, and

SGT Steve Wosgien – 10 FSB

*Arte Et Marte*

### EESW RAEME CRAFTSMAN ARTICLE

The year has seen a changing of the guard at Electrical and Electronic Systems Wing (EESW). MAJ Gwenda Casperonn has arrived as the new SI, fresh from polishing a seat in Canberra. LT Michelle Sheather (RAEME) has become the platoon commander of Electrical Platoon while LT Keith Tan (RASIGS) looks after Electronics Platoon. WO1 Nick Hooper has positioned himself comfortably in the ASM Electronics chair while ensuring everybody's service writing is up to standard. Due to WO1 Trevor Gifkins taking discharge, WO2 Craig Mcleod has taken over the role of ASM Electrical.

The amalgamation of the electronics ECN's 419, 420 and 422 into ECN 421 has been progressing well, and nearing the final approval stage. The training packages have been developed in preparation for the implementation of ECN 421.

There have been several new equipments and upgrades introduced into service requiring extensive integration training. For Radar and Guided Weapons Section, the Rapier B1 Surface to Air Guided Weapon System has been given a life of type extension, by purchasing the B1MLI (Mid Life) system. In addition the Automated Artillery Meteorological Systems (AAMS) has been fully re-fitted, resulting in the course package being rewritten to incorporate the system's GPS capability. This kept WO2 Tony Roylance busy, as he was the only one qualified.

Technician Electronic Systems Section is headed by WO2 Simon Hurdle and he and his team have had to amend training due to the ASLAV upgrade. The ASLAV has been upgraded to the phase 3 turret which includes GPS, electrically driven turret and laser rangefinder. The section is also eagerly awaiting the opportunity to provide training for the RBS-70 VLLAD-WS Land 19 upgrade, which is due to be implemented in the near future.

Combat Net Radio Section has had to develop training for the upgraded RAVEN shelter. The revised RAVEN Medium Level Maintenance Course has been reduced from 16 to 8 weeks. In addition, for the first time, technical instruction of the VIC – 3 Intercommunications Harness has been successfully incorporated into the medium level course. The section is controlled by WO2 Kirwan Williams which ensures the laid back lifestyle is maintained.

During the year, we have also managed to program in a swimming competition, Tug-of-War competition, a 15 km force march and a six-day field exercise.

The ALTC swimming carnival was held on March 26. This resulted in a win to EESW, helped by the fact it was virtually the only wing with female competitors. Thanks to the efforts of

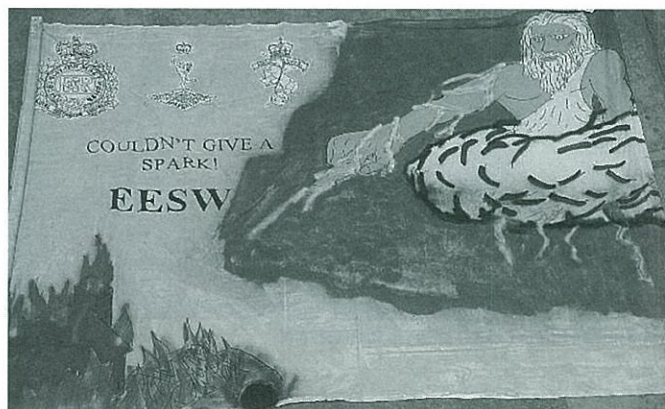

The winning banner

PTE Chris Prins, CFN Barnard Lincoln and CFN Matthew Mcgregor, EESW managed to win the unit banner design competition which was held in conjunction with the swimming car

The MSD Tug-of-War competition started off with several training sessions conducted by SGT Rod Potter. The trainees approached the training sessions with dedication and enthusiasm. On competition day, stand out performers were PTE Chris Ellul and CFN Matthew Brailey, who performed as coaches and team members. Unfortunately, despite all the dedicated training, the other wings performed better on the day, resulting in EESW coming last.

The next event on the calendar was a 15 km force march, commencing out on the Hume Weir and ending at Latchford Barracks. The pace started out slow but increased when our Infantry WSM, WO2 Peter Courtney and SGT Tex Saunders took the lead, which enabled the wing to finish in the dedicated time limit. All members who participated in the event finished, although some limps and blisters were evident. The event culminated in a division BBQ, followed by the traditional early knock-off.

Most recently, EESW participated in Exercise "Broad Horizons". In traditional army fashion, a significant family day, Father's Day, was chosen as the departure date. The wing boarded the buses and headed for 'sunny' Puckapunyal range, to begin the six-day field exercise. The exercise consisted of IMT training for the first phase and a section level competition named Exercise "Trained Soldier" as the final phase of the exercise. Of the five sections from EESW, the overall result saw our teams finish second, third and fourth out of 19 sections. On the whole, it was a very pleasing result for EESW.

With the field exercise concluded, training at the wing continues. The remainder of the year will be busy preparing for a "Beating the Retreat" parade on 29 Nov 03.

*Arte Et Marte*



WO2 Darren Cardwell's ammo resupply stand on Exercise Trained Soldier

## 5 AVIATION REGIMENT

### A SQN

The last few months have been their usual hectic selves for the A Sqn TST. May saw A Squadron deploy 3 aircraft and 2 FRTs to Perth, and 2 aircraft and an FRT to Sydney. All involved worked tirelessly to ensure that the end result was expertly prepared aircraft and equipment for the duration of the exercise.

A Squadron went to Sydney again in June with 4 aircraft and 2 FRTs. After a small break, we were again being tested with a large ROE including putting on-line up to 6 aircraft per night for a Special Operations course in August. We are currently moving the entire squadron to Sydney in order to support the Rugby World Cup, (hopefully including us catching some of the games ourselves if possible). To support this effort we are taking all of our aircraft, all of our tradesman and all of our gear – big move, should be great fun!

The TST is looking forward to a well-earned break at Christmas on return from this push in Sydney.

### B SQN

B Squadron, the workhorses of the Regiment were again extremely busy deploying in a number of exercises and operations. In August, the Squadron conducted a full-scale deployment exercise in order to hone their skills, and confirm that they can indeed operate at a high level in the field. All tradesmen within the Squadron worked tirelessly to maintain their ROE for the duration of the exercise.

The Squadron is now shaping up to commence Exercise Croc in September, where they will deploy 4 aircraft to the region. This will be a great test of what the Squadron has already learnt, and allows them to show the rest of the deployed units what the Buccaneers are truly made of.

*'Go Buccaneers'*

### C SQN

C Regt TST has continued its post-"land of sand" recovery. It has been an interesting time for the Cavemen, working tirelessly to ramp back up to the pre-deployment standard of general housekeeping and admin, especially with the C Regt ATR at the end of August, and the preparation for Ex CROC in September.

We are now moving forward with more modifications and continued capability enhancements giving 'C Regt' the technological advantage for our next theatre of operations! The trainees are using this time to their advantage, and we now have five additional tradesmen in our Caveman ranks - congrat-

ulations and good work to: CFN Baxter, CFN Hartnett, CFN Harward, CFN McGeary, and CFN Payne. Also, welcome back to CFN Hortle who has rejoined us after a stint as a civilian - it is good to have you back.

Finally we wish SGT Mark Williams farewell. Mark is leaving the TST to be with his family over in Perth. Unable to be co-located through the Army we wish him well with his new life as a civilian; we will miss his easy going nature and sense of humour! (Anyone got any jobs going for a Chinook Blackhand SGT in Perth?!)  
*Go the Cavemen!*

### TSS

Technical Support Squadron hosted the RAEME mid year function this month, and once again record crowds flocked to the Pegasus club to Quench their thirst. The function was attended by most units within the North Queensland region creating a great gathering of old and budding alcoholics. One of the highlights of the evening was the Gladiator Podium manufactured by Ground Equipment Repair Troop. Corps members battled through the night representing their respective workplaces. As the ale flowed, the battles became less structured and eventually turned into random corked legs and wedgies. A great night was had by all, and it is good to see esprit de corps is stronger than ever.

Congratulations to SGT Amanda Edwards on a much deserved promotion. She has worked tirelessly over the last year, being deployed to Timor, and as a role model within the MCS. The promotion is recognition of her efforts during this time. Well done!

On a more sombre note, TSS MCS had to farewell one of their popular sons in September, with the transfer of CFN Travis Hillier to the RAAF. The Squadron wishes him well in his new line of work over at the dark side, and would like to extend our appreciation for his services to 5 Aviation Regiment over the entire time he spent here. He will be missed by all.

### ART

As usual, 2003 has been a busy year for Aircraft Repair Troop (ART). Members have been involved, deployed or detached in support of various organisations and activities. These include OP Bastille, ship-borne exercises, manning support to Aviation Support Group Workshop and the ongoing commitment to OP Citadel. The rest of the year is shaping up to be no different with commitments to OPs Scrummage and Citadel.

In amongst the hard work though there has been time for some troop bonding. The most notable of these events was the now bi-annual "Tour de Townsville" pub-crawl, ably led by CPL

## PLANET PAINTING

- ★ Domestic
- ★ Industrial
- ★ Commercial

Defence Projects Undertaken

Covering NSW & Qld

Enquiries to Steve Dimeski

**0416 213 737**

## STRUCTURE SCADES QLD PTY LTD COMMERCIAL LANDSCAPING SPECIALISTS

Major Defence Contracts Undertaken

Enquiries to Todd McCorkell

Phone: 3208 9337 Mobile: 0414 374 837

Email: structurescapes@optusnet.com.au

## SENTINEL INDUSTRIES (Qld) Pty Ltd MAJOR ELECTRICAL CONTRACTORS

- Austel Licensed • Access Control • Security

★ Commercial ★ Industrial ★ Domestic

DEFENCE CONTRACTS UNDERTAKEN

Phone Stuart Dykes: 5547 6422 – 0409 158 414



**Scott Walsh JP**

NSW Workshop Manager

10 Bruncker Road  
Chullora NSW 2190  
PO Box 518  
Greenacre NSW 2190

Ph: (02) 9796 9993

Fax: (02) 9796 9990

Mobile: 0418 289 177

Website: www.toll.com.au

Brett "Not another penalty stroke" Fitzsimmons.

June saw the intrepid adventurers from ART head north to take on the mighty Tully River. Lead by guides Doug "The River God" Merry, Nigel "I wanted to flip there" Ellis, Megan "Midnight Rock" Webber, Mark "I didn't want my bailing bucket anyway" Wagstaff and Adrian "The love boat" Luke, members of ART paddled, swam and tumbled their way from Alarm Clock to the Tully Recreation Park. Other activities included measuring the combustibility of wax boxes, chasing rats (thanks Niels "Rat Man" Sletering) and watching State of Origin. Thanks to all those who gave their own time to make the trip a success – you know who you are!



'Ok, who dropped the spanner'



Croc ... what Croc?'

The future also looks bright for ART on the technical side of things. The remainder of the year will see the establishment of an engine bay service section that will serve to keep the Regiment's Black Hawk fleet provided with power well into the future. The engine shop will provide a significant increase in maintenance capability to the Regiment.

Finally, congratulations must go to all those members of ART that have been promoted this year: CPL Dunn, CPL Wardill, CPL Post, CPL Pregnall and LCPL McCulloch.

## REGIMENT SPORT

Even with the high-tempo environment, and hard working RAEME personnel at the unit, a number of REGT and Representative teams achieved outstanding results in the last few months.

Cross Country – The 3 Bde Cross Country event highlighted the huge amount of talent we have within the Regiment. After a gruelling 8.5 km course including a painful climb up Brigade Hill (more like a mountain), 5 Avn Regt posted some of the most competitive runs of the day. CFN Genn was our best-placed male in 10th position overall, with CFN Moc coming in just behind him in 24th position. CAPT Elizabeth Stephens came across the line as the first placed female in the race, and was awarded female champion for the event.

Netball – Recently the NQ netball competition sent down 3 representative sides Womens, Mixed and Mens to compete in the ADF Netball Carnival held at HMAS Cerberus, Melbourne. All three teams did extremely well with all teams finishing third in a very tough competition. Through all the training and competition, the 5 Avn reps had some individual success with many members making the Australian Defence Force side in their respective divisions.

CFN Matt Clapham made the All Star Seven side for the Mixed, and CFN Sonny Davies made the Men's Australian side.

Well done to all those players who represented the Unit and congratulations to those members on their individual efforts.

Rugby – The 5th Aviation Regiment plays as part of the Brigade Commander's XV Rugby Union Football Team in the 3rd Brigade Rugby Union Competition. This year the competition was cut short due to the high operational tempo incurred within the Brigade with many Units being deployed on various operations and exercises throughout Australia and overseas.

The final competition was contested between 1RAR, B SQN 3/4 Cavalry Regiment & Commander's XV in a 'Round Robin' format which ultimately eliminated one team before the grand final. The two teams that reached the 2003 Grand Final were B SQN 3/4 Cavalry Regiment & The Commander's XV. The final result was 42-9 in favour of CXV.

Players from 5 Avn Regt that were selected to play for CXV in the Grand Final were CFN Travis Hillier (illustrious captain), CFN Zane Mitchell (recently returned from Army Rugby commitments) and LCPL Marty McCulloch. Well done to all!

Obstacle Course – After months of hard training, blood sweat, tears, and some shear guts and determination, the two teams of 5 Aviation Regiment Obstacle Course Warriors battled for the top position. After just over 13 minutes of blistering performance over the wet muddy course, both teams posted magnificent times.

At the end of the rugged battle between all of the 3 Bde teams and the mighty 5 Aviation Regiment cohort, the male team took the crown and first position, with the Women doing exceptionally well to achieve third position. Well Done!



'I told you walking around the pipes like everyone else is quicker!'

## 21st Construction Squadron Workshop

by CPL Ian "where's the RAP" Seeley

The year 2003 for the workshop has been a rather busy year given that it is our online year. For a change, the article on the workshops this year is going to headline the many characters in the Workshop as well as touch on some of the activities we have been involved in this year.

The commencement of the year saw many new faces arrive in Brisbane; however, for that to occur, we lost a number of personnel. The people who left: us in 2002/03 are:

### SPECIALIST SCAFFOLD SERVICES

Commercial & Industrial Scaffolding Specialists

MAJOR DEFENCE PROJECTS UNDERTAKEN

ENQUIRIES to MICK COLLINS

3890 1477 ~ 0439 773 730

### AI INTERIOR LINING

Interior Lining Specialists

★ Commercial ★ Industrial ★ Domestic

DEFENCE PROJECTS UNDERTAKEN

Phone Graham Fredericks

Ph: 3823 4644 • Mobile: 0411 743 898



Capt Ellsworth – R.M.C.  
 Sgt (now WO2) Coup - JLU SQ.  
 Sgt Chiverton – 8/12 MDM REGT.  
 CPL (now SGT) – Gaylard ALTC.  
 CPL Finch – 1FLD.  
 CPL Clarke – QLD Police.  
 CPL Franklin – Won't tell.  
 CPL Baum – JLU N.  
 CPL Plumridge – SASR.  
 CPL Giersh – 22 Const Regt  
 CFN Bradshaw – Mack Australia.  
 CFN Bennet – 7 CSSB.  
 CFN Hilton – RAAF School Wagga.  
 CFN Bishop – ENZED.

**The New Crew**

The new crew is headed by the big Neil Diamond fan, Capt "where is my brew" Evans. This man keeps telling us he has no money but we have seen his oil well. His able ASM WO2 Tony "I got the rapper" Monagle ECN 006 or when swearing, ECN 235-2, has been busy staying out of trouble even when he apparently told the few women in the SQN they were spastics. Capt Evans replaced LT Clunas who remains in the unit but has no idea where she is or what colour her hair should be!

Our four snakes this year are certainly different. First of all there's Sgt Mick "I'm not Lord Farquard" Davies, who stands four foot six and is yet to go through puberty. Mick has to yell or have an "O" group to get his point across. Next we have the RPS Sgt Andrew "I'll change things around here" Grubb. The good Sgt has improved the section to the point where he can get any HDT Commodore part the same day he needs it.

Sgt Darryl "I'm not the bloody biscuit boy" Allen, has kept his remedial swimming to a minimum to concentrate on the three hundred odd jobs he inherited. At last once he can swim the same amount of laps as we have jobs. And then there's Sgt Jim "I ride bulls" Beaman, who brought the country to the city with wild stories of fishing and shooting while the sounds of country and western plays in the background.

Then there are the corporals. CPL David "the blues are all right" Booth put his hand up to help the boozier sell raffle tickets. He sold all the two dollar tickets in record time by charging only one dollar. CPL Matt "I promise I won't spew" Burns

drove into the car park in a Ford and has told us how good they are ever since. CPL Jim "feel how wet it is in here" Ellis returned from PNG with a lot bigger personality and a larger stomach. After a nasty incident in PNG Jim now takes an umbrella to his mossie dome at night.

CPL Chris "hair is over rated" Green is using the horse and carriage technique this year, he sits in his chair and whips into line all those in front of him. CPL Mark "I don't know, throw it in the bin" Hager spends lunch time totally relaxed with a nice cup of herbal tea as he plans his next move. CPL Mick "that happened in Timor and Bouganville" Kenny has perfected the bandaged knee, to the point where no-one even asks if he's doing PT. Last and probably least there's me, CPL "I'm going to the RAP" Seeley when I'm not whinging and whining I'm constantly looking out for things to whinge and whine about. And I have it on good authority that this is a true and accurate representation of me.

CPL Ben "Car-Chew" Carthew has just recovered from a serious finger injury, that saw him sidelined for six weeks from a simple catch of a tennis ball, that went horribly wrong.

The workers consist of CFN Mick "I'm bloody huge" Buttler (and so is his gut). His laugh during Jerry Springer is so funny, the closest thing I can compare it to is a big cockatoo. CFN Jeremy "this is starting to sh\*t me" Cochrane is running the C Veh chop shop. Apparently a gas axe will undo even the most stubborn bush.

Believe it or not we have a set of twins CFN Scott "I'm not wobbo's brother" Considine. and CFN Todd "where's my stack-hat" Rutledge. Scott arrived with a reputation of being a little different and is yet to prove that's not the case. Todd is currently receiving HDA for corporal because if he did tow something (not likely) he would do it by himself. However unlike his predecessor, Todd has yet to bog the un-boggable MRV.

CFN Edward "pay your bills" Field, decided it was a lot easier to punch the sapper than follow them. Pte Mark "I can't believe this" Fitzgerald has spent all year proving the English are the most annoying race on earth. CFN Brad "pink means STI" Furber spends his day dreaming of working on fast cars. But until then the high powered 110 rover and the turbo 6x6 will have to do.

CFN Anthony "yeah I'll show you" Jung has been busy promoting his movie Joe Dirt, and word is his next movie has a lot of horse riding in it.

CFN Andrew "butt-larr" McBurnie was given the job of testing MAS, it took them a long time but they found all the faults. CFN Eric "I've got a flat dick" Purkiss purchased all the coke machines in the Enoggera area so GE is only a depot and the GMV is the delivery truck for his thriving business. CFN Damian "look's fine to me" Robinson the most experienced mower mechanic in GE. Robbo has had war-



**BAYSIDE HYDRAULIC DESIGN PTY LTD**  
 Commercial and Industrial  
 Hydraulic Design Specialists  
**Major defence projects undertaken**  
 Enquiries to Paul Webb  
**Phone 3821 6933 – 0438 222 116**

**LA CONSTRUCTIONS (QLD) PTY LTD**  
 CARPENTRY CONTRACT JOINERY SPECIALISTS  
 • Commercial • Industrial • Domestic  
 Defence Projects Undertaken  
**Enquiries to Nola Alderton 0439 410 900**  
**Lance 0421 080 809**  
 Brookwater



ranty work keeping him flat out all year – including his own mower four times. CFN Wayne “don’t let fear and common sense hold you back” Schulz not only does he sleep walk and talk, he takes a leak on other peoples mossie domes while he’s at it, apparently.

**Ex Puk Puk 2003**

The squadron was involved in a Defence co-operation project exercise in Papua New Guinea titled Ex Puk Puk 2003. The task was a joint exercise involving Australian engineers and the PNG Defence Force Engineer Battalion re-building 900m of road, refurbishment of three barrack blocks, ablution block at Warrior wing as well as a number of tasks of opportunities. This task was conducted at the Goldie River Training Depot, which is about 30km from Port Moresby.

The workshop element for the exercise consisted of 8 Australians and 5 members of the PNGDF Engineer Bn workshop. The Australian contingent consisted of ASM/Welder (when it suited him) WO2 Tony Monagle, RPS PTE Mark Fitzgerald, GE CPL Jim Ellis, ELEC CFN Eric Purkiss and VM’s CPL Matt Burns and Chris Green, CFN Ben Field and Wayne Schulz.

The advance party consisting of the ASM and greasers departed on the 12th of June to conduct maintenance on PNGDF plant equipment before the main body arrived. The container with all the required workshop equipment didn’t arrive until the 23rd of June, when the main body arrived, so the advance party struggled along with a leatherman, a piece of rope and some big hangovers, apparently.

Much of the plant equipment surprised the workshop with its ability to carry out the taskings with minimal repairs and maintenance. The main dramas with the plant was blown hydraulic hoses, so much of the workshop time was spent under a shady tree or playing cricket in the workshop yard. When it was noticed how little work Eric had completed the engineers requested his electrical expertise on one of the building sites. It was from this point that he became know as SPR Purkiss, the useless engineer bastard.

The ASM and Ben Field seemed to enjoy creating Hydraulic fittings so much that the ASM had to have two goes at welding some of them together. Other tasks for the workshop included the fabrication of the 130 ceiling fan hangers, 50 laundry

bench brackets, 50 bathroom bench brackets. With each of these jobs the ASM fabricated a perfect example (just ask him) and handed over the job to Jim Ellis. It must be said it was a good thing the ASM fabricated the prototype as Jim tried to reinvent the right angle with his 88-degree square.

The workshop also took on the task of refurbishing the children’s park at the married quarters which chewed up a considerable amount of man-hours but was worth it when it was seen that the park was packed with smiling kids from sun up till sun down.

As the task drew to a close it was decided it was time to pack the container for return to Australia. All was going well until we needed to unpack the hose swage three times in as many days from the back of the container. Eventually the doors were shut and the project finished. Good byes were said to new mates from the PNGDF Engineer Bn and the detachment returned to Australia on the 15th of August 2003.

**Tonga**

Sgt Jim Beaman has led CPL Hagar, CFN Robinson and CFN Todd Ryan (7 CSSB) on a mission to build a two story building in Tonga. The project has progressed very well and in part it is due to the ongoing support to the Construction Troop by the RAEME detachment. There has been no dirt to report so they say, but watch this space in the next edition for updates.

**Bike Wash**

All for a good cause – our ASM washing Boothy’s Harley Davidson. After Boothy won the raffle for the ASM’s car spot and a wash of your vehicle, to raise money for our end of year function. Note that he has to read the instructions first as per the TRAMM.

That was it from 21st Construction Squadron Workshops. As you can see we have a number of personalities and throughout the busy year, they have had to opportunity to sport their wears both at home and abroad. From the Wksp to you all.

*Arte et Marte*

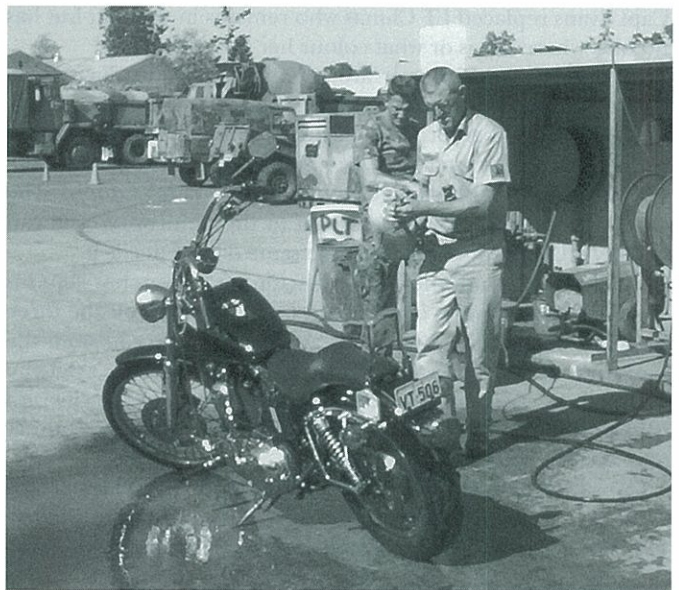

**M.L. STEFFENS TRANSPORT**

Step Deck Tilt Tray – 20 Tonne Capacity  
 – Semi Trailer  
 General Haulage  
 Contact Murray

**Phone 4751 6649 • Mobile 0427 169 826**

Townsville

**MRS BUCKETS CLEANING SERVICE**

SERVICING TOWNSVILLE & SURROUNDING AREAS  
 Commercial – Industrial – Domestic  
 Office Cleaning – Exterior Cleaning  
 Builders Final Clean

**Contact Sandra 0418 726 914**

Kirwan

## 5/7 BATTALION GROUP TECHNICAL SUPPORT PLATOON – AUSBATT VII EAST TIMOR: OCT 02-MAY 03

*Two hundred and something days in paradise ...?*

### EMEOPS

by WO1 Ray Morgan and WO2 Scott Langham

The original manning structure of the deployment saw some late changes, which greatly effected the make up, and the numbers, that would be deployed to support the Battalion group. The changes included some cut backs in trade numbers, but where possible most people saw some operational time, either in alternative positions or for a reduced period on one of the three-month rotations.

The entire workshop toiled hard over the seven months that AUSBATT 7 spent in East Timor, and all the lads enjoyed the experiences gained whilst here. They have done themselves proud, producing a high quantity of excellent work and kept the fleets around the country going in some very trying conditions.

The boys have thrown together a few comments on the trip, which they have compiled over their time here. To all the people who served or assisted our lads during the deployment – the entire workshop thanks them for their efforts. I should also mention that our ASM (Ray Morgan) will be taking discharge on return to Australia after the deployment. To Ray and his family – we wish him the best on his retirement from the Army.



L-R: WO2 Scott Langham, WO1 Ray Morgan and WO1 Craig Moffat enjoying the ASMs farewell dinner at the Mess at FOB Moleana

### EIR

SGT MARK PETRIE  
CPL MARTIN DODD  
LCPL MARK SAVRON (5/7 CSST)  
CFN JOHN BANKS (5/7 CSST)  
CFN LACHLAN BUCHAN  
CFN DAVID DERKSEN  
CFN JASON PRINS (2/14 QMI)

### Electrical Section by Electrical Section

ELEC section, consisting of Doddy and Buchy have had a constant work load over the last seven months, proving to all why we earn pay group 5. We have been constantly on call and working on the diverse range of equipment over here earning our keep. Equipment we have been maintaining includes generators, fridges, 240 and 415 volt power, auto electrical, washing machines, dryers, air conditioners and any other item electrical or otherwise that no one else could fix.



ASM WO1 Ray Morgan getting some quality time out of the office

Not only have we had to do the workload at Moleana we have been out on many FRT's around the AO, as well as the odd market trip where time

has permitted. All in all it's been a pretty good tour with plenty of work done and experiences gained

### TELS Section by CFN Prins

The TELS section at Moleana had a change in manpower in early January with SGT Mark Petrie saying goodbye to take up an instructor's position at ALTC. Thankfully though the deserved reputation of Radio Mechanics being the best looking tradies was up held with the arrival of CFN Prins via 2/14 QMI.

With the hectic and very strenuous task of testing all that Raven equipment there was a fear that boredom could claim the first AUSBATT 7 casualty. Then without warning and might I say interrupting a damn fine afternoon sleep our Fijian friends, decided they would like their Hi -Tech 77 set radios repaired.

This sent our "good-looking" section into frenzy as long forgotten trade skills were rediscovered between bouts of surfing the Internet and long lunches.

Congratulations to CFN Derksen and CFN Prins on holding up that long held RAEME tradition of only doing it as hard as you have to.

On a personal note from myself, thanks to the lads at 5/7 RAR Tech Support for their support in the time leading up to and following the birth of my son. I have had a top time here and look forward to working with you again. Thanks also for sparing me the typical 5/7 RAR ramps down initiation!! Frenchy you know I'm talking to you!!

### Instruments Section by LCPL Savron.

Instruments section had to opt out of the 'best looking tradies' category this tour due to the large amount of time spent actually doing trade work - especially the endless stream of Ninox equipment and that anxious call of 'can't get the battery out'.

However, our good looks and experience did pay off in Dili where CFN Banks and myself amassed large crowds of fans wherever we went. They kept calling us 'Mister Jiggy Jig' – which apparently is Tetum for 'we are very impressed by your handsome western looks and baggy green pants'. We took the compliment without hesitation and paid back their kindness by buying some of their nice CD's.

Overall, 7 months is a long time anywhere – especially away from loved ones. Fortunately we have had a safe trip, been with an excellent workshop and learnt a great deal – trade and cul-



PTE Ritchie with some good quality Moleana-mud face cream

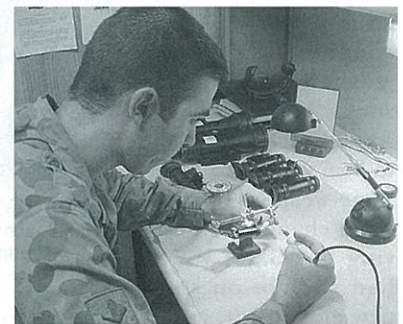

LCPL Savron repairing night fighting equipment

## AAPEX PROJECT SERVICES

- Concrete Repairs • Crack Repairs • Waterproofing
  - Epoxy Floors • Joint Sealing
- Specialising in Cementitious Repairs  
Contact Steve

0408 701 872 • Fax: 4723 8057

Email: [steve\\_patchy@bigpond.com](mailto:steve_patchy@bigpond.com)  
PO Box 185, Aitkenvale 4814

ture wise from the experience, which is all that one could really ask for.

Only one question remains – what time does our plane leave.

**GE**

- CPL CRAIG DONOGHUE
- CFN NIGEL WALLIS
- CFN MARK GOIRIS
- CFN STEVEN 'I AAAMMM HUUUGGGE' COSSTICK

GE Section, consisting of CPL Craig (Crash) Donoghue, CFN Steven (Coz) Cosstick, CFN Nigel ( I only need 2 hours sleep a night) Wallis and CFN Mark (Frenchy) Goiris, has been enjoying new challenges over the seven months of deployment to East Timor.

We have had a busy time throughout the whole tour - Tony and Coz took it in turns to look after APC troop at Tonabibi for the first half of the rotation until SGT Quirk from 2/14 QMI took over the armourers duties in early January.

Frenchy spent most of the tour stuck at Moleana welding absolutely everything from glass to concrete and was often told that he worked extremely hard and often worked until late into the night to get a job finished.

Wal had fun keeping the LEC's (Locally Employed Civilians), whipper snippers and lawn mowers in tiptop condition as for some reason they love to mow rocks. Wal and Crash scored a chopper ride to Suai via Dili to repair some weapons, it was a good change from driving the GMV. We all had to take on some new equipment, as well as trying to talk slower to the VM's, stopping them from eating their crayons and proving that EIR can neither justify or deserve pay group 5.



CFNs Vaughan and Zimpel conducting a powerpack lift

We found time to get to Dili for a few days to see the markets and a Thai massage was much better than a back rub from the Physio. We also found out that GE has much better looking people in it than the other sections. . . well, according to hot or not that is.

**RECOVERY**

- CPL SCOTT "RICHIE" BERNAU
- CFN NATHAN "SCOTTY" SCOTT
- CFN ANDREW "PRANGER BOY" SMITH

The Recce Mechs have had an interesting time in between brews. Richie and Scotty have been all over the countryside in the MRV keeping every one out of trouble, from lift tows, to stopping Engineers Graders from rolling over into rice paddies. We have had a steady stream of work, obviously picking up in the wet and dying off in the dry.



CFN Krummenacher doing his bit to keep the fleet going

The Boys had a late addition to the ranks with Smithy for a week in April before losing him to an APC drivers course. Richie and Scotty only have one

question, to the Ace, "where's our trip to Suai to meet the Slovakian nurses?"

**RPS**

- SGT CRAIG BOWDEN
- CPL JM LAURIE (BI STORE)
- LCPL DARREN HANN
- PTE CRAIG DUNBABIN
- PTE FRASER RICHIE
- PTE RICKI-LEE KNOX

Things have gone well in the RPS with everyone working very hard, however, I haven't been here as long as the others. I've heard some interesting stories, for instance the 20ft Connex that was completely loaded with loose parts and empty boxes with no paperwork. It sounds like I missed out on all the fun.

The rest of the boys tell me that they spent weeks on the computer – and in and out of the Connex trying to find anything that resembled a stock code or even a part number sometimes working late into the night.

More recently though Dunny had to go down to Batugade to help remediate the RPS prior to it being moved back to Moleana. The APC lads had no storeman and the high workload provided little time for the store upkeep and Dunny did a good job rectifying the situation.



CFN Goiris and his team of locals stocking the new steel rack at FOB Moleana

Now we are counting the days until we get to go home to see our families and maybe even sneak in a nice cold beer. All the RPS staff have enjoyed the experiences but are looking forward to our return to OZ.

**VEHICLE**

- SGT L.H. MITCHELL
- CPL MICK HOPPER
- CFN ANREW DEWHURST (5/7 CSST)
- CFN DANIEL FOYEL (2/14 QMI)
- CFN DARRIN HOWELL
- CFN FREDDY KRUGER
- CFN MARC KRUMMENACHER
- CFN DARRYL PORTER

Well, what can I say?

We started the tour in the usual fashion, with people finding any number of problems with their recently acquired pieces of kit. Just as the scene was looking a lot better, the dry season was ended by cyclone MAS, inflicting a 90% casualty rate amongst vehicles. The team in Vehicle Section worked exceptionally hard to get the vehicles back on the road, enabling the Battallion to continue with its tasks. After the storm passed, and numerous hours of 'Over Time', the VM's once again proved that they are the back bone of the Defence Force!!! (A third class ride is better than a first class walk any day.)

The VM's showed their talents, with the Elecys spending 5 hours – (No exaggeration there) trying to get a generator going, enter the VM 10 minutes later, problem solved lets go home. Another justification of pay group 5, no doubt.

The grunts kept us busy with a constant flow of used and abused vehicles entering the workshop daily. With a few expletive remarks and our tongue's held in the right position, the boys knuckled down and got the job done in an exceptionally

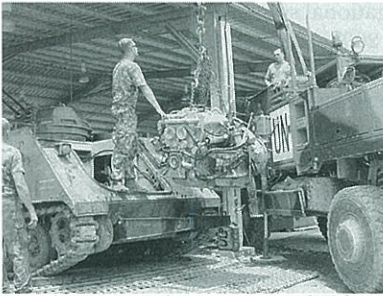

**L-R: LCPL Lockett, CPL Bernau and CFN Scott conducting an engine lift**

after every joy ride around the countryside.

In the good looking tradie stakes, it was clear that CFN Darryl (I'm a 9.4) Porter was the winner by a unanimous points decision. This was later over ruled when the Mareeba Experiment decided to try and up the point score and failed dismally.

All in all, a good tour was had by every one. Especially by 'Mister D' who has entered himself in the Maliana Mayoral race by constant bribery of the local kids with Bon-Bon's.

## APC ECHLON

SGT ANDY PETHYBRIDGE  
SGT STEVE QUIRK (2/14 QMI)  
CPLLENNY LEHMAN (2/14 QMI)  
CFN PADDY ZIMPEL (2/14 QMI)  
CPL TONY EARWAKER  
CFN JAMES FIELD

After training all year for the deployment it came as a shock to find that we would be deploying in a combined workshop and that we would be split into two, three month rotations, (apart from Lenny and Patty who saw out the whole tour). The Ace was delegated to 0A, and soon was running the Battalion - advising the various Coy OCs on how to tactically deploy their men in various situations that would arise. The shock was noted on their faces when it was realised that a spanner was telling them what to do.

The APC echelon was initially a combination of both 5/7 RAR and 2/14 QMI personnel for the first half of the rotation. The echelon worked very hard to keep the M113 fleet rolling and they saw countless FRT's, covering many miles and did a mountain of servicing to maintain these invaluable assets. The efforts were notable with some pers changes taking place including the services of Tony Earwaker and Steve Cosstick in the first rotation taking care of the armourers duties. Dave Derksen also worked hard on the radios for the troop and lent a hand where necessary on all fronts.

Lenny was kept busy most of the trip recovering the crews from various predicaments and had the pleasure of recovering the only APC to drown. No Cav were in the area at the time. Patty was to see out most of the tour servicing the fleet, it must be noted that if it wasn't for his efforts and skill the troop would not have been able to function as effectively as it did.

Foyelly on the other hand was to remain at Moleana with the main workshop and from all reports picked up some new skills in B vehicles. As the mid tour rotation came around it was good to see Quirky and Prinsy finally make it into country.

professional manner.

Our most prolific customer proved to be our favourite Gunnies. This paled into insignificance compared to the amount of time that the MRV spent on the workshop floor. The poor beast was scrubbed, buffed and polished to within an inch of its life

From the smile on Foyellies face, I think he was glad to be heading off home.

In early January there was a changing of the guard with SGT Andy Pethybridge handing over the reins to SGT Quirk who quickly picked up the pieces of the Ech and created a harmonious work environment for us all down at Batugade. He was kept fairly busy running the show and doing the armourer jobs for the endless drivers and turret courses.

Prinsy was to head up to Moleana to see out his tour fixing various televisions and the odd radio. We received Vaughny from the CSST- (when CFN Field returned home in early February with Andy). He took over driving the fitters and he seemed to enjoy his time with us. As the trip comes to an end we are all looking forward to getting back to Brisbane and enjoying a well-earned break.

## ENGINEER WKSP

CPL DEANO ALCOCK  
CPL RUS GEELAN-ASHCROFT  
LCPL MARKO BRAN  
LCPL KIBBLE  
CFN RICHARD KELLY  
CFN JUSTIN NIELSEN

The Engineer boys lived up to their reputation of living hard and treating their equipment with the same disdain. The Engineer workshop worked tirelessly to sustain the engineer elements of the Battalion group and allow them to keep up the arduous tasks of maintaining the lines of communication.

The initial push saw CPL Alcock and his off-siders come to Tonobibi to take over the maintenance liability and produce some credible efforts. In early January LCPL Kibble and LCPL Bran rotated back to Australia and this provided CPL Geelan-Ashcroft and CFN Neilsen the opportunity to show their wears.

The only effort notable of mention is the fabled Dili fishing trip. The emphasis of the trip was not about the one that got away but rather the one that got caught This element of the workshop worked very well producing tremendous effort in East Timor to maintain and improve the quality of the engineer equipment

**5/7 RAR TECH SUPPORT – AUSBATT 7  
EAST TIMOR**

## 2nd Cavalry Regiment – TECH TROOP 2003

by *SGT Kiwi Sommerville*

Well, the year started as usual with a lot of rain, high humidity, flat batteries and no one wanting to be in the northern-most capital of Australia – a nice welcome to the tropics for the newcomers of which there are quite a few. Starting from the top Major Justin Hutton is still the boss of Support Squadron with Mega Ace (Regt ASM) WO1 Dave Clarke up from the ASLAV Program. ASM SPT /Tech Tp Leader (Mini Ace) is WO2 Russ Peet with section heads SGT Norm Schonrock (Veh) from Cav, SGT Wayne Tutt (Recovery), CPL Paul Bean (GE) and SGT Kiwi Sommerville (EIR). Vehicle section is made up of some very colourful characters including CPLs Tim McDougall, Greg Penno (to take discharge later in the year), "Mouse" Armstrong (marched with discharge pending) and LCPL Steve



**Members of Tech Spt PL enjoying Christmas in the mess at FOB Moleana**



**SGT Bowden assessing the damage as he works out where to start on a container full of RPS with no documentation**

Freiberg (promoted later). The real workers were CFN Damian Van de Velde (who later took medical discharge), Ryan Hoy Poy, Nick Van Tuinan, CFN McFarland (marched with discharge pending) and Shane Hingston. Recovery had only one individual apart from Tutty and that is CFN Ashley Boxall, who is yet to do his recovery course. Boxy was developing a relationship, which was to flourish during the year, which did, and is, making him the butt of several jokes – all well intentioned I assure you. Next is GE, which held the characters of Andrew Noble (who later took medical discharge) and Metalsmith Cameron Salter (who later took discharge). We also had CFN Stevens but he didn't put in a show until 4 days into the final ex due to course, spending some time in B SQN and Op Relex (who also elected to take discharge).. Finally, the elite section within 2 Cav, EIR with LCPL George Cooke (elec, posted mid year) and new march-ins CFN Ben Grace (Inst and Radio), another one taking discharge early 2004 and CFN John Gray (inst and ASLAV). As can be seen the workshop was low on players which is not unusual throughout the Army but it always seems to hit hardest at home, however we were helped out by the placement of Manpower personnel to assist in the servicing and repair of regimental vehicles.

The yearly program started out with all good intentions but as all that care know, the plan went into a tailspin quickly when we had to send a Troop to Iraq in support of a platoon from 2 RAR to protect the Australian Embassy. This happened over the Easter stand down period and people were called in from leave to prepare vehicles. The next weekend was the ANZAC Day long weekend we were all called in again for that one, because the make up of the vehicles we were sending changed and we had to prepare different vehicles. Later in the year preparation for Predators Gallop and Croc 03 was interrupted when we had to put a Squadron on stand by to go to the Solomon Islands, but this never eventuated. We were also involved in a Regimental Ex at Pine Creek and several minor exercises with the other squadrons to a lesser degree supplementing their personnel and replacing those involved elsewhere. This has made for a full year culminating in the last major ex, "Keldie Cup", "Flashing Sabre", "Predators Gallop" and "Croc 03" during the months Aug and Sep in sunny (and extremely dusty) SWBTA.

CFN Ryan (HP) Hoy Poy shone this year with his second attempt at a motorcycle course. Last year he was on a course, but the third day brought some difficulties – staying on, and he broke his left arm – his wife wasn't happy. This year he managed to complete only one full day before those dreadful things, inertia and gravity struck again and young HP took another tumble, over the handlebars this time – similar result different arm, wife still not happy. He may have attempted his last motorcycle course.

I attended the familiarization course for the new Phase 3 ASLAV turret systems that enter service with the Regiment in early 2004. The course was conducted at ALTC Nth Bandiana, apart from freezing (why do they plan these courses for mid winter ???) I came away with high regards for the new system. For those who don't know, the present system within the Gen II/Phase II vehicles has hydraulics driving the traverse and elevation of the turret and gun. The new system is electric with an in-built turret processor similar to the Leopard computer system allowing for a "Lay" function (leading the target) which should, with practice, allow the crews to achieve first round hits on moving targets. It also has a very impressive navigation system encompassing a GPS with the IVNS (Intra-vehicular Navigation System) which after calibration computes by dead reckoning or by the use of the electronic compass mounted at the rear of the vehicle. Overall a massive improvement to

the gun platform and navigational systems.

The first ex this year was 200kms down the Stuart Highway to Pine Creek where the normal Regimental activities took place with a couple of notable exceptions. The first concerned the preparedness or willingness to participate of the majority of Tech Tp who failed to react to an "enemy" attack and were told in no uncertain terms to get their \*\*\*\* butts out of bed. Then there was the incident concerning the interaction of a razor-back and one of our tame roaches (RPS), young PTE "Stitch" Jones who at the time had been in the process of carrying out a perfectly natural bodily function. When he came running out of the bush and said "a pig has just had a go at me", the question was "was it as good for the pig as it was for Jonesey?"

Now, the ex that we were all looking forward to – 3000kms south east to Shoalwater Bay Training Area, the "premier" training area in the world if you are to believe the signs and excuse the ticks, the dust, the water, the cold and the distance required to get there. It started well for the majority of Tech Tp at about 0730 on a Sunday to commence the six-day drive. Remember young HP, well he is now driving one of the vehicle sections 6x6s towing one of the new 1250 kg trailers (new name "Christine") with medical supplies and 2.5 kva generator and he is travelling quite well. Most uncharacteristically the vehicle suffers a blowout in one of the front tyres whilst traversing a corner prior to a bridge, he handles this drama with nonchalant ease but has the trailer flip and hit the side of the bridge – minor damage only. Later his front drive shaft decides to break so the vehicle is recovered forward and Christine is passed to another 6x6. This 6x6 was also travelling okay until Christine arrived when they blew a rear main seal and also had to be recovered forward – look out the next 6x6 which after hook up suffered a prop shaft failure. Christine was put behind a mog – she really only wanted to be dominated.

For once there appears to an abundance of tradesmen (never too many) with all the new march ins and OJTs attached to us for this ex. We also have two Kiwis attached to the unit for the duration, both gun plumbers over to have a hands-on look at the ASLAVs in preparation for the arrival of their Phase III cars (slightly bigger and no swim capability). So apart from the drive down things have been business as usual with the greasers getting the bulk of the work, as it would seem that the bugs have been removed from the new DTAS sights. Radio is still snowed under due to lack of serviceable equipment but this goes all the way up the chain so everyone is suffering. During the breaks the OJTs are been taught the basics of life in the weeds, Hunt the \*\*\*\*, 500 and various other card games, how to bash dixies etc.

Before finishing, I have been told to include an additional listing of the Tps personnel to include the mid year march-ins and the OJTs. We have additional to veh section CFN "master of useless information" Greenstreet, CFN Wall, CFN "Montgomery Burns" Clarke and CFN Steve Sheather. We also welcomed CFN "Lolly" Lollback into recovery and CFN Geoff Hanley into EIR. OJTs were CFN "Terry" Venables and CFN "Stuart" Little (VMs), CFN Williams (Fitter) and CFN Ash Duncan (OJT). We say farewell to CPL Steve Freiberg who is off to Kapooka, CPL Tim McDougall off to 1 FD Regt and L/CPL George Cooke IRR in Sydney.

The OC MAJ Justin Hutton is off to Canberra for his sins. He has enjoyed his time here way too much. Some say he is the best Digger in the Squadron. If you can't find him in his office (which you rarely do), you will find him under an ASLAV helping out with spanner in his hand, in the RPS sorting through stores or sweeping the floor in the Q Store.

As a final note to put with this each of our line squadrons have a tech spt section with them. At present we have a number

of personnel from C Sqns TSS overseas in Iraq supporting an element of their squadron performing protection duties. They are WO2 Pete Williams, CFN Jeano Jean and CFN Fred Zukowski. Soon to be rotated through are SGT Bill Stoddart, CPL Brennan and CFN Anderson.

2003 has been a hectic year with the Regiment jumping from one activity to another. The good thing out of it appears to be the opinion that we have finally gained the approving eye of Canberra and seem to be one of the first options for future deployments. Next year brings us brand new ASLAVs and new challenges. So if you want to be posted to a Unit with modern equipment and a real opportunity to go somewhere put us on your postings wish list.

## 2HSB – 2ND HEALTH SUPPORT BATTALION

G'Day. The time has come to put this little unit level Wksp on the map and give all you out there an appreciation of what a posting to 2HSB could be like. Like many over my time in the big green house it was very easy to perceive the idea that a posting to the hospital had respite written all over it. You don't go field very often so you aren't away from home for extended periods which in the current environment maybe what everyone at some time or other is looking for.

Working with the medics has imposed a lot of maintenance challenges. Their priority for outplacement training at the local hospitals and other 7Bde RAP's as well as deployments in East Timor and Solomon Islands has made it very difficult to maintain any continuity as far as personnel available to do all the operator tasks. Currently on our 4th resit for TRAMM compliance the unit looks to another audit at the same time the MED and DENT fleet managers arrive to give us their two-bobs worth. The release of VERS 4 SDSS will have a big impact on us next year as we are still double handling EMEFIX's and all ye whom did the training are getting posted.

Medical Corps celebrated its centenary this year with a march through the city. 2HSB has just celebrated its 3rd birthday with a parade and a family day.

Manning for this unit is as follows:

ASM – SGT Debbie Young (posted 1CSSB)  
 CPL VEH MECH – CPL Michael Patching (posted 3CSSB)  
 CPL TECH ELEC – CPL Paul Scarr  
 CPL BIO-MED TECH – CPL Jason Turk  
 CPL ENG ELEC – CPL Reg Grundie (posted 21 CONST SQN)  
 CFN FIT/ARM – CFN Gregg Matthew's and  
 SPR CARPENTER – SPR Damian Stephenson.

Most of us have worked together for 2 years now and it has been a great team. Sgt Young has worked tirelessly to attempt TRAMM compliance and trying to establish procedure for MED & DENT repair. For her 1st year as a SGT I think 2HSB will miss her more than she thinks.

Patch has done a sterling job carrying the units deficiency of no Prod Clerk and Barman. He will be moving into a SGT'S spot at 3CSSB (best-o-luck dude!)

Scarry is very sad to be seeing them posted and dreams of getting back into a GMV. (Hopefully in Cairns) 2004 maybe his testimonial year!

MR T (TURKS) has spent the last 3 months on HMAS MANOORA and I have no doubt he will be glad to get home.

Reg has had a good year with golf and promotion courses and he is off to AACAP land. Gregg is in the middle of pursuing a transfer to the RAAF and watches as many live bands as possible. Stevo has just settled in and is renovating the units' boozier. It's been real good working with the TSSU guys this year and may everyone have a good break over the Xmas standown period.

*Arte et Marte*

## 51 FNQR Technical Support Platoon – Fact, Fiction and Myth



51 FNQR is based in Cairns but has staff and equipment located on Thursday Island, in Weipa and Mt Isa. There are also numerous equipped and bare patrol bases. The Unit is predominately made up of Reserve members

that form six man patrols which are capable of deploying by land or sea. The Regular members fill most of the HQ, Ops Spt and Training positions, similar to NORFORCE and the Pilbra Regt.

Technical Support Platoon (TSP) has approx 32 positions of which there are 9 ARA slots, including a lone Fitter in Thursday Island. It is anticipated that TSP will be eventually lead by an ARA WO2 ASM.

The main role of TSP is to maintain (IAW the TRF) the Unit's equipment using local contractors and integral Unit tradesmen to support Unit activities. Some of the activities supported this year have been courses (approx 12), operational and training patrols and 4equipment trials.

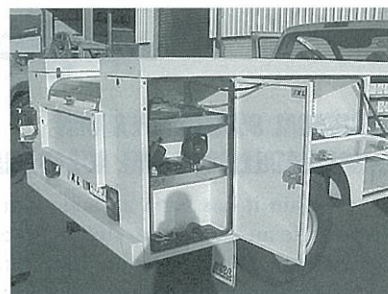

A unique challenge to TSP is the diverse range of equipment used by the Unit. From RFSVs (70 odd), almost as many boats with OBMs ranging from 25 to 250 HP and an array of electronic gear used to capture and transfer images and data. The work is picked up from non techs, EMEFIXs and regular inspection/ repair FRTs that travel by air, land and sea through out the AR.

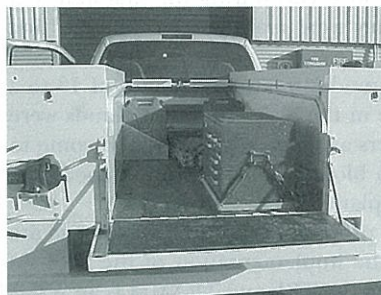

To carry out our role the workshop owns one GMV, two RFSVs (necessary for mobility and integration into patrols) and a 7m work boat. Additionally TSP this year have gained a Ford F250 (4x4, diesel 4.2l, 6 cyl) fitted with a standard XL work body. The

F250 is being trialed as COTS solution to remediate a deficiency in GMVs that 51 FNQR had.

The increasing Unit maintenance liability, reliability of GMVs over long distances on badly maintained dirt roads and the requirement to carry an increased payload (tools and parts) dictated that a COTS solution would best resolve these issues for 51 FNQR. It was agreed within TSP that the traditional GMV type module (read overweight campervan) was not suitable in the interests of maximising permissible payload, which for 51 FNQR, means maximising technical



support as far forward as possible through increased tooling and parts availability at Emefix/job location. The XL work body (there are numerous other companies that produce similar products) was seen to be ideal as it provides weather proof, secure and accessible storage space for tools and parts given its relatively low weight. Keen punters should note that this configuration provides 25 per cent more payload capability than a GMV but has a GVM of less than 4000kg (GMV 5600kg). Just imagine what you could carry if you fitted an XL type body to a 110 6x6 cab chassis!

In the future TSP is looking forward to the replacement of most OBMs, the introduction of new Tier Two boats (we know boats), TRF accreditation for all depots, running up some miles in the F250 and an escape from a SDSS V3 and a half black hole.

P.S. If there are any ex-ARA tradesmen out there looking for plenty of ARES days and live in NQ or are considering a move to paradise please ring the Workshop, we need you!

*Arte et Marte*



## TECHNICAL SUPPORT PLATOON — 3RD BATTALION, ROYAL AUSTRALIAN REGIMENT

Once again it has been a hectic year so far due to the normal reasons, ie an exercise to support every month, people away on courses and 20 year old equipment. Well enough of the sarcasm this year has been busy due to the re-establishment of the Parachute Company Group (PCG) and Parachute Battalion Group (PBG) roles within 3 RAR.

As a result of the focus being on parachuting and not Timor, the same old members of TSP were out doing the airborne thing nearly every month and the same old stayed behind pretending to work. Isn't it amazing how priorities arise when a jump is nearing but can not be arranged to get the boys out of company parade or the likes. There were many fingernails chewed and a lot of cold sweats during the first jumps at the start of the year and they were mainly from the guys that stayed back.

TSP was bolstered from a modest platoon strength of 13 to a hefty 19 thanks to a change in the SED. The extra hands were soon filled with tools or risers as the new guys tried to come to grips with jumping out of a bloody good (or fully Functional, according to TRAMM) aeroplane.

Any way enough airborne propaganda, the major job for the start of the year has been the implementation of the TRF. As everyone involved in it knows the TRF and TRAMM is an ASM's nightmare to implement. After a lot of hard work by the mem-

bers of TSP, 3 RAR is ready for the TRF audit in October.

EME Ops has been steadily plodding along, usually organising postings to places like Tamworth and discharges for themselves and pretending to organise the busy ants below.

GE has been busy, with CFN Rocky Reeves and CFN TASTY Hynds pretty much running the show whilst the new additions are finding their feet. CFN Boxhead Hardy has been busy on courses to bring him up to speed for life in the Battalion, and LCPL, Back Pocket Boy Pavitt is trying to come to grips with working in the Battalion, rather than sitting in his room playing the playstation, as he did in his previous life as a grunt.

The main action this year has been within vehicle section, the work as always never seems to end, because as we know there is no equipment that is grunt proof. But with the extra hands it seems to be slowing down slightly.

CFN That's not sh\*t in my pants Vickery has been the course guru for the section, and with CFN whingeing Whitey leaving CFN Wingding Wayne Long has stepped up to fill his boots, there must not have been too much to this job as Whingeing Wayne took about an hour to take control.

It was good to get a few extra sets of hands to make up for the admin twins CFN I AM THE PARA GOD Short, (even though I can not jump) and CFN I went to Timor for 2 weeks and got my money Murphy. We are sure they are doing the admin for the whole section.

The newest addition to the section is CFN Babyface Smith, he seems to be settling in well and we are hoping to have him out of his nappies within the next few months.

Leading up the vehicle section is CPL Get your feet together when you're talking to me Nolte. With him leaving 3 RAR to become a RI at Kapooka, he has been trying to practice his authority on the newer members of tech support but he hasn't yet master keeping a straight face. CPL Nolte has been occupied with his new toy the FLSP (skid lube) which he is taking to EX CROC. At one stage this vehicle was not go to end up on EX CROC after the ASM discovered Nolte was planning to set it up so it had beer and rum on tap inside of OMD 115 and OEP 220.

TSP have struggled over the past few years to find a roach that could do his job, that was until we got CPL Vern The dining in night king Andrews, Vern worked out that the best way to clean up the store was to return everything and hold nothing. We can now at least get the RPS on a truck instead of having to call in Toll Transport to move it around. Vern's new additions are PTE's Ross (Soup) Campbell and Manny (wheelbarrow) Daellenbach.

We do also have an EIR section, these are the guys that get called to orders and once in the sunlight start to melt. EIR is lead from the front by the midget of the platoon CPL Tom (I am standing up) Manning, the course guru for this section would have to go to the course man him self CFN Brian (I want to be something, but I don't know what) Corrigan. With Corro always on course Billy (I haven't been sleeping) Mckid has been busy reading the local papers and surfing the net.

LCPL Sticks McGovern has been our OJT (Our Jack of all Trades). He is preparing for life after infantry and is looking forward to attending his course, if he gets one.

I would like to take this opportunity to say these articles are a chance to have a bit of fun and also to let others know what goes on in the airborne workshop. I hope that the above mentioned people have taken this article in the jest that was meant. If not than Harden Up Princesses.

*Arte et Marte*

### Members of TSP 3 RAR 2003

WO2 Terry Cassidy – ASM  
SGT Mark Moran - PL SGT

CFN John Hardy - GE  
CFN Matthew Hynds- GE



CPL Vern Andrews – RPS  
 CPL Tom Manning – EIR  
 CPL Nick Nolte – VM  
 LCPL Glen McGovern – Token infantry  
 LCPL Mark Pavitt – GE  
 PTE Ross Campbell – RPS  
 CFN Brian Corrigan – EIR  
 PTE Manny Daellenbach – PROD CLK

CFN Wayne Long - VM  
 CFN Dave McKid - EIR  
 CFN Dave Murphy - VM  
 CFN Tim Reeves - GE

CFN Ray Short - VM  
 CFN Tim Smith - VM  
 CFN Scott Vickery - VM  
 CFN Ramon White - VM

**'HELL WEST AND CROOKED'**

by CFN Neil 'Neddy' Smith

Yet another full on start to the year for TOTAL SUPPORT PLATOON 25/49 RQR. The workshop has managed to single handedly hold the Unit together again! It started in a blaze of glory with Exercise SANANDA where our part time friends and new march-ins were all wondering what they were doing, starting the year in such a hurry.



CPL Morrisey

Into the swing of things and the workshop vengas bus cruised down the highway of army life as per normal.

Admin Coy deployed south to the gold coast for our annual exercise white pointer in February and the workshop again led the way in fine athletic bodies and kicking butt on the

beach sporting field. But the main event of the day, obtaining female beach goers phone numbers was again won by the workshops very own pool cleaner/homebloke CPL 'Donkey boy' Kirkpatrick.

We welcomed SGT Deta 'is that a moustache or did my eyebrow come down for a drink' Kerschat who had time to march in, get a sunburnt head, buy a house he did not want and then go straight to Bougainville.

Our new EIR march in CFN 'I'm have'n a durry' Robertson maintained the fine tradition of cars that make you think how the hell did that get a roadworthy. His presence brings the number of chrome domes in the workshop to three. When the month of March came around, CFN 'Neddy' Smith was off on holidays/research trip to the UK, to discover the subtle variations in KFC.

April was indeed a sad month for the workshop. It was a month in which we finally bid farewell to LCPL Eugene "HEAD" O'dell. The custodian of the golden hammer award every week for the last six months, for outstanding achievement in the field of stupidity. Who could ever forget the timeless classic reply to CFN Stirzakers comment?.....

CFN Stirzaker "I heard this guy got booked doing 195km/h in a 60 zone"

To which LCPL 'Head' O'Dell replied "Wow that's almost twice the speed limit".

AHH the memories!!!!

LCPL "HEAD" O'Dell is off to Bandiana. We are all hoping that they have a yellow shirt big enough to go over his head. If anyone runs into HEAD don't forget to ask him to share one of his golden memories with you and remind him that he does have a large red headed melon, he sometimes forgets you see. Please help us to keep the dream alive.

We welcomed back, after a short lay off due to injury, the new

brew king CFN Steve 'Stumpy, Combat Egg' Morrissey. The brew club did not know what hit it. The muffins barely survived two days in the fridge before being inhaled. Good luck on civvy street Stumpy.

We also saw CFN 'JUDD' Perry trundled off to get 'edumacated' to become a pilot. We think it was just so he could wear the overalls and nice gloves. Apparently he had his boots off for the first maths test. He is now back in the workshop and is taking up the role left by CFN 'stumpy' Morrissey, which entails a four-day week with no weekend work. Because of this, Judd is now also known as ST2(Stumpy mark II).

CFN 'accident prone' Stirzaker went into hospital to see if they could strengthen his limp wrist. The results are unknown at this stage but on a better note he has made it to June without having an accident. Very disappointing for our RAP as they had posted in two new medics just for him! We have reassured the RAP that we are only halfway through the year and there are plenty of 'speedy sleeves' to be knelt down on yet.



CFN Stirzaker and Fealy



Young Eugene 'HEAD' O'Dell

Late May saw us welcome back to the workshop CFN 'stretch' Smith from sunny Bougainville. We are told he maintained the high standard of eating ice cream and kicking the kiwis off the RAEME table.

CFN 'Shakey' Collins has all the storemen pitching tents and the

local small furry animal population very nervous, strutting around the workshop with chaps over his shorts and priceless booty protectors on. Well at least he is no longer a medic and giving us needles. That's scary!!!!

The newest but oldest member of the workshop CFN 'back in my day' Bryce kept morale high whilst at a live fire range shoot. During his clearance he boldly begun the declaration only to be shot down in flames when it was pointed out to him that he was still holding a full mag. Two days later he tripped over a green ant at PT and was out of PT for a week. The poor young fella needs to learn about being a crafty in the modern army because his production figures are way too high. But with encouragement and guidance from Stirzy and Ned, we are sure this will soon be brought under control.

CFN Fingers 'but that's not how we did it at 17 construction' Fealy has had a big start to the year. Not only did he nearly complete the first week of sub 1 for CPL he spent a tough week or so supporting the driver's course/fishing trip to sunny Shoal Water Bay. Apparently the crabs where this big and you should have seen the one that got away, 'Just like the ones we used to catch at 17'!!!.



CPL Walker

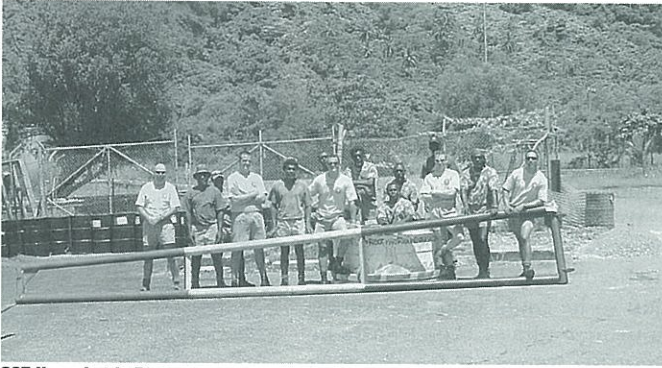

SGT Kersch at in Bogos

The new ASM, WO2 Jordie Alfred Burgess, burst onto the scene with a new car every week and finally deciding on a power packed shopping trolley Suzuki Mighty Boy. Apparently he has ordered a Harley Fatboy but we are yet to see it.

Together with his brew buddy SGT 'loose guns' Cannon the boys are yet to decide who is the better volleyball player. Between Sgt Cannon knocking himself out on the sand court and the ACES rule changes the Boys think they make a lovely couple and could see them tying the knot sooner rather than later, they already have the wedding car.

LT Green in his 's#\*t-box Landruiser' was off for the first six months of the year recruiting the Officers of tomorrow. His main areas of operations, from what we can gather, are the beaches of WA. He has not recruited a single person yet but he has obtained at least ten phone numbers, some of which actually belong to females, we just don't know how many!

So we sail into the next part of the year only looking forward to what excitement lays ahead and what free stuff is at the next spanners club.

Arte-et-Marte

## 1 RAR BN GP AUSBATT VIII OP CITADEL – TIMOR LESTE

The Unit's second tour, but for many of us our first. Off we headed into the sunset dreaming of the beers and skittles to be issued on arrival. With the AUSBATT comprising of unit's such as 3/4 CAV, 3 CER, 3 CSSB and a lone tradie from 1 CSR, we had an exceptional Tech. Spt. With plenty of depth for our tour.

### The team comprised of the following people:

ASM WO2 Mick 'Ace' Harris; Never seems to get tired of beating us at darts (especially Pagey). Runs the rock show, runs blocker between us and the headshed.

SGT Ian 'Z' Aitken; Where's my thongs and heres the piquet list. Has a fetish for P.T. thrash sessions.

SGT Nathan 'Davo' Davis; Suffers from guichi-shiney kit syndrome, very familiar with e-bay, always looking for a bargain, specialises in lifting, towing and recovery of the dead.

SGT Dion 'Deadly' Taylor; Likes his guns, big and loud, likes his crafties small and quiet



CPL Jamie 'Can We Go Home Yet?' Bath; Looks after the parts we can't get, cleans up the shit-fights we leave in the RPS and subsequently will probably have a stroke at a young age

CPL Matt 'Blah Blah' Brooks; Unfortunately when the conditions of service changed, had to change his favourite saying from "This is a war-stopper!" to "This is an op. Stopper!"

CPL Toby 'The Mouth' Everson; Greatest winner in the world or at least in his section, forever trying to bet against Bob's Rabbitohs

CPL Bob 'Country' Mitchell; Loves his Casey Chambers, his Buckets and his Rabbitohs

CPL Andrew 'The most beautiful man in the cosmos' Page; Is extremely good looking, just ask him. Great darts player (this bit was written by him). Keeps his section in line with 'interesting' tactics.

LCPL Pete 'Old Man' Douglass; Enjoys the Emenien, slim dusty, darts and high fibre diets, stills remembers when his brother was in Timor with the 2nd/1st Independent Commandos in 1942

LCPL Colin 'Russian Col' Goulding; Just like the energiser bunny, never, ever bloody slows down!! Ever! I can't stress this enough.

CFN Daniel 'Snailsford' Brailsford; One eyed, plays with ones and zeros, even sleeps with his radios, all around good-guy and devil-may-care fool

CFN Adam 'The Clown' Currie; Having the entire FOB in fear of his alter-ego and another e-bay addict

CFN Damien 'Bat Booth' Gott; Must have had the most attractive brew mug because people kept taking it.

CFN Ben 'Holiday' Hewlett; Always parked up with JL drinking brews, smoking durries.

CFN Brent 'Gingernuts' Jones; Fixed all the Med and Dent stuff then went home after 4 months (piker).

CFN John 'Office Bitch' Lennon; Creator of the "Blah Blah" and co-owner of Ben and Johns Green Machine Vehicle Team.

CFN Peter 'Blondie' Lovelock; Always first with P.T. enjoys his phone calls and midday naps, lives in fear of the clown, and spends way to much time in the booth

CFN Pete 'Nugget' Matten; More road kill notches on his GMV than anyone else, fixes air-cons as a priority

CFN John 'Muppet Arms' Mewett; Barks like a terrier, fights like a poodle, always doing bodgies or playing with guns

CFN Chris 'The Riddler' Newman; Should be working for intel or the MP's with all his questions, also the maggot of the platoon.

CFN Grant 'Man boobs' Paulsen; Keeping everything serviced and loves playing with his Merlo's

CFN A 'Noisy' Spornoick; Great guy, good in bed, excellent tradesman, just never shuts up!!

CFN Jim 'Gravox' Went; Made a fashion statement with the reverse mullet, always concerned with his calcium intake

## B VEHICLES;

After the initial 'transition', the heart and soul of Tech Support were required to inspect every vehicle in the AO, phew, yeah no worries. 11 days later, done and we had some comfort in knowing where we were positioned. Then it was the waiting game for the bloody parts. So 70% of the fleet lay grounded, littering the beautiful gardens of Moleana. To date, we currently are running at 100% efficiency, and the gardens are looking much better. This workload spawned a birth to what we affectionately know as the 'Blah Blah'. A highly sophisticated piece of data retention and calculations software, that tracks each vehicles movement and current status in terms of classification and km's till service. The section head Matt "This is a war stopper" Brooks used the knowledge from his previous two rotations to keep assets on the road and moving. Brooksie

loves a prank and had Benno going good, needless to say the favour was returned with much enthusiasm. Grant Paulsen, who has previous experience with Merlos, got (for a better word) shafted with taking care of Magic's Merlo as well as the Royal Title of OIC Servicing. Chris Newman, being the maggot of the platoon, just did what he was bloody told! In the middle of the tour, had the luck of doing a king-of-all-swan-trips to Dili for a two week alleged drivers course. Needless to say his hand was the first one up for FRT nominations from that time on. The poor bastard had to 'celebrate' his 21st in country, which proved to be a minor success thanks to 'holiday' and 'JL'. Beers (ginger), cokes (cola), females (clothed) and gambling (fake money) filled in the afternoon nicely. 'JL' proved to be too good at IT matters and subsequently filled the office bitch and data entry position nicely. 'JL' with 'Holiday' were also considered to be partners in crime, often accused of 'parking up and smoking durries'. 'Holiday' is usually never far from a coffee, cigarette, his 'battle tranny' and a yarn. Enjoys helping keep Winfield in business and has developed a taste for the local coffee. Then there was Jimbo, readily available for those more interesting (gravy) jobs. Using his previous mine experience to man-handle some of the challenging jobs tasked to him. Never short of a yarn, or a bitch for that matter. 'Russian Col' managed the job allocating, parts ordering and occasional hands on work when required. Always knee deep in RPS's which keeps the rest of us away from the loathed task. Col is like the boss, his there when you arrive and still there after hours. After all the hard work was laid to rest and we could take a step back to review our tour, I think we are fairly pleased at what we have done for the technical support of AUSBATT VIII.

*CFN Ben Hewlett & CFN John Lennon*

### 3 CER FRT

Hello from East Timor. Well our trip is going as planned, both myself and CFN Anatole (Blood nut) Sopronick are hard at it fixing nearly every piece of kit we have.

With the inclusion of 1 RAR Assault pioneers, our job doubled and as a result there has been no fishing or swan trips to Dili. Though we do get the odd couple of games of league on the tele. Go the Doggies.

Seriously though we are enjoying our trip and are looking forward to returning home to our families and starting a fresh year with 3 CER.

*CPL Toby Everson*

### EIR

As always EIR is the heart and soul of tech support platoon and there is no wonder with three crafties running there own rock shows. CFN Jones (Jonesy) is our resident window licker and has been hard at work during his time with Ausbatt VIII but sadly must leave with his replacement being CFN Happel (Happy). CFN Matten (Matto) is constantly busy looking after all of our electrical jobs and on occasions he is noted for his sense of humour and clowning around. CFN Brailsford (Brailsy) when awake, repairs our communications in an air-conditioned office with his apprentice CFN Butler (Butts). We are all enjoying our time in East Timor but look forward to our return home to see loved ones.

*CFN Daniel Brailsford*

### GE

In the General Engineering and Armaments section, the true heart of any Tech Support, is a very dedicated and professional team of tradesmen (fitters). Cpl Andrew Page does an out-



standing job of the day to day running of his section and without flaw. He is surrounded by a dedicated bunch of craftsmen who assist in keeping the Tech Supports image looking as good as it does at all times. Cfn Adam "The Clown" Currie has been kept busy by the heavily tasking of weapon repairs. His efforts have not gone unnoticed and has been rewarded with a posting to Marine. Cfn John "Muppet Arms" Mewett has been heavily involved with the enormous task of keeping the Engineers happy from inspections and repairs to there weapons on small engines and other intricate fabrication jobs. He has performed to a level above and beyond his call of duty and has also been rewarded with a posting to Marine. Cfn Peter "Blondie" Lovelock, although a late calling to the team, has not faulted in his professional approach to his work. Without Peter's long hours and diligent service to the Corp the section would not be able to function as smoothly as it has. I pray that he may also be rewarded with a posting to Marine. In summing up I would personally like to thank my section for their efforts and congratulate them on a job well done. Hopefully Cpl Page will be rewarded for his efforts with a posting back to Marine.

*CPL Andrew Page*

### CAV

To finish off this all round team was APC WKSP. This was comprised of SGT "DAVO" Davis the toerag, SGT "TAILS" Taylor the gun plumber, CPL "BOB" Mitchell, CFN "BUTTS" Butler, CFN "GOTTY" Gott the greasers and the lone boffin CFN "BRAILS" Brailsford. CPL Mitchell running the greaser side of the house steered us through the ordinary hand over and the MAS visit with only a few all nighters early on in the tour. Our first outing to the range only lead to a day of recovery training with no bullets down range. If that wasn't enough SGT Davis has kept us busy with Recovery and Tandano jobs. SGT Davis being the only Tandano operator outside of Dili with his two trusty dogs Brails & Butts.

*CFN Dave Butler*

At the time of writing this AUSBATT VIII has about 2 months to go on it's tour. The first elements of Tech Support leave country in 4 weeks (14 Oct 03) leading into the handover to AUSBATT IX (6 RAR) and the return of the rest of the unit to Australia.

We eagerly anticipate our return to Australia all cashed up with much bacchanalia.

We also wish everyone a very Merry Xmas and all the very best for the new year.

*Arte Et Marte*

*CFN Ben Hewlett & CFN John Lennon*

## 16 AD REGT EX CROC 03

by CPL Latham and CFN Luxford.

G'day to all from the guys at 16 AD REGT TST. Well it's bush time again and the boys are doing it hard in Shoal Water Bay Training Area (the bay). Our fearless leaders B1 and B2 (CAPT Fullick and LT 'cuddly bear' Sibeneler) graciously opened their tent up in the evenings to become the TST cinema. Cold coke and hot popcorn with melted butter soon became the SOP's for watching DVD's.

Vehicle repairs kept the VM's busy on the long boring drive from Adelaide to the bay. Once the travelling was complete the VM's (Heaven, Hirdy, Nick and Brown) settled into the daily routine of brewing up and watching videos. The unshakeable Cuddly Bear was somewhat disgruntled by the apparent lack of manners shown by the plethora of dead kangaroos on the side of the highway as they all seemed to be chucking 'brown eyes' at him!

The techs (Boardie, DJellio, Lathe, Curbs, Lucky and Ranny) were busy maintaining the serviceability of the Rapier kits throughout the exercise, but maintained high morale through taunting Cuddly bear and our lone storeman Harry. The GE boys, Skins and Kacks, fixed a couple of generators and did the odd bodgie or two. Kacks was lucky enough to be picked for a platoon 'observation and harass' patrol up North, but all he did was sit on a beach and soak up the sunrays.

Just to break up the monotony of the toastie/brew up routine, CAPT Fullick, CPL Heaven, Nick and Lucky volunteered to harass some recon elements at Williams airfield just up the road with a couple of tag alongs from 110 Bty and our RP CPL Griegy. Super grunt CPL Grieg managed to set off an early warning party popper early in the piece but everything was pretty quiet with our clearing patrols coming up empty handed. As we were preparing to pack up shop and hand over to a 2 Cav element a convoy rolled in allowing us to successfully capture the first prisoner of the war. Some of his classic quotes were "who's in charge?" Reply "we are", "can I speak to my boss out of EX", "no", "but I'm on an admin move", "not anymore". But perhaps the best one came after the casual stroll towards seven of us in enemy cams (all training rifles at him), "are any of you guys movers?", "We are now get on the ground!"



The Capture Party – (Back L-R): CFN Luxford, CAPT Fullick, CFN Pirie, CPL Heaven, GNR Freeman. Front (L-R): PTE Bull, CPL Greig

## 9TH COMBAT SERVICE SUPPORT BATTALION – DEPLOYMENT TO PARNKA POINT, COORONG



On the weekend 31st May – 1st June 2003, eight members of Recovery Platoon, 107th Field Workshop, 9th Combat Services Support Battalion deployed a Mack Truck, two Medium Recovery Vehicles (MRVs) and two Land Rovers to Parnka Point in the Coorong region of South Australia. The objective of the deployment was to assist Rangers from the Department of Environment and Heritage to remove wrecked civilian vehicles from the area.

The Platoon deployed at 0700hrs on Saturday morning, having completed preparations and loaded the stores and equipment earlier that morning. The early departure time was largely thanks to the efforts of WO2 Pammenter, SGT Riches and SGT Schmidtke who worked from very early in the morning to prepare stores. CPL Separovic gave a set of convoy orders prior to the Platoon leaving Warradale Barracks.

2LT Renfrey and SGT Riches met Mr Eric De Wits, a Coorong National Park Ranger at 0930hrs at Salt Creek and discussed plans for recovering the vehicles. The rest of the Platoon arrived

in convoy 30 minutes later. We determined that two vehicles would be recovered from Parnka Point and that it would be possible to cross onto the beach at the Tea Tree Crossing, thus saving 26km and several hours on the round trip.

After a short halt, the Platoon departed Salt Creek at 1100hrs and com-



menced the 37km journey along the beach to Parnka Point. The Tea Tree Crossing was negotiated with ease despite the high tide making the water depth approximately 500mm. The going along the beach was very good for the majority of the journey, however the sand became much softer over the last 8km. One Land Rover became temporarily bogged, but was easily towed out by a MRV.

At Parnka Point, the wrecked vehicles were easily located and the Platoon began the task of hooking them up to the MRVs. The back wheels and axels of both casualties had seized and meant that the Platoon had to use oxyacetylene equipment to separate the diff and unseize the back wheels. With much banging and burning by CPL Separovic and crew the two vehicles were eventually made towable and the Platoon left for Tea Tree Crossing at 1600hrs.





With the sun rapidly setting the Platoon made good going back along the Coorong beach, stopping only to collect firewood. The Platoon set up camp for the night at Tea Tree Crossing. WO2 Pammenter organised a modest size bonfire (by his standards) and SGT Riches cooked up a feast on the Company BBQ.

The Platoon rose early on Sunday morning after a rainy night under canvas and prepared to head home. The Platoon stopped at the Ranger's station at Salt Creek to drop off the two vehicles and pick up another wrecked vehicle (recovered by a 107th Field Workshop team in September 2002) which was destined for the scrap yard at Murray Bridge. We also had the advantage of cleaning the sand and salt water from the vehicles with the Ranger's high pressure cleaning equipment.

At Murray Bridge, CPL Separovic and LCPL Raymond led the operation to unload the casualty from the Mack truck. The operation was made tricky by the fact that the wreck lacked tyres on several wheels and refused to travel in a straight line. With great effort and eventual success the wrecked vehicle was safely unloaded and left with its grateful new owner at the scrap yard.

The Platoon returned to Warradale Barracks at 1600hrs on Sunday afternoon, refurbished stores and cleaned our vehicles again.

The deployment was a great success and all members had an enjoyable experience. The newer members of the Platoon gained valuable recovery and off road driving experience in challenging conditions, whilst the more experienced members of the team updated their recovery skills with the valuable refresher training. We will be actively looking to participate in similar DACC tasks in the future.

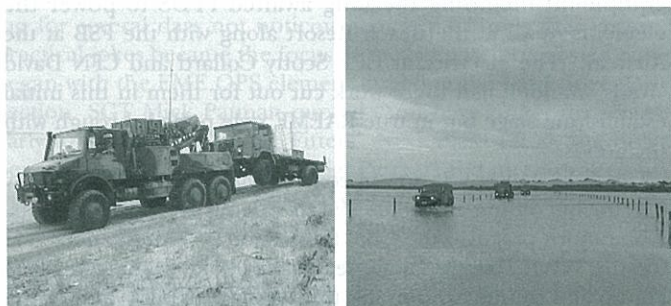

## 107 FD WKSP, 9 CSSB

by 2LT Eugene Wasilenia

The past twelve months have seen more than the usual run of changes and challenges presented to the Workshop. Despite our status as a GRes unit (or perhaps because of it), we have worked hard to acquit ourselves in these turbulent times.

2003 began with the regular changes in personnel after the posting cycle, the Workshop bidding farewell to MAJ Ian Cartland, MAJ Buck Rogers, CAPT Alan Wilson, LTs Rebecca Irwin and Ian Stewart, WO2s Grant Kuchel and Doug Pammenter. In return, we welcomed OC MAJ Dick Moyses, 2IC CAPT Peter Reynolds, OPSWO WO2 Shane Buckley, and CPLs Craig Smith (Vehicle Platoon) and Chris Venning (EIR Platoon). Throughout the year, we have been fortunate enough to have our numbers bolstered by new march-ins for each of the platoons, with varying degrees of military experience among them. Additionally, the command element has welcomed two officers newly-graduated into the Corps (2LTs Craig Williams and Lucien Tasovac) and the return of two officers from the inactive list (LT Penny Mayman and 2LT Ben Renfrey). Meanwhile, potential disruption to the Workshop has been kept in check by the guiding hand of the ASM, WO1 Noel Thomas.

The implementation of SDSS and the TRF has caused headaches for all concerned, especially the small complement of ARA cadre staff. However, change is inevitable and these changes have brought us closer into line with the rest of the Army. To keep things interesting, we have adapted to form FRGs for the CSST environment, as well as providing personnel for the new Reserve Reaction Force. These developments will doubtlessly ensure the 9 Brigade AFX will be busy for all concerned. With AIRN and All-Corps Soldier Training added to this mixture, somewhere we still find the time to receive jobs and carry on with production work – proving the rule that our Craftsmen can achieve anything.

## 102 FIELD WORKSHOP

### 3rd COMBAT SERVICE SUPPORT BATTALION

Normally I would get a CFN/CPL from each of the Pl to write an article for the magazine detailing their daring exploits over the last 12 months. This has proved to be difficult this year as the Wksp currently has 2 Offr: 19 ORs in East Timor, 1: 21 in the Solomon's and 1: 26 in SWBTA for CROC 03, leaving a total of 33 pers from the OC down left to battle on. Strangely enough at the SED review 12 months ago, I was told that there would never be the requirement to deploy 3 x FRGs and have a Wksp, but as the ASM has told me, 'never say never'. These deployments however are a good reminder that regardless of which of the 3 Bn's from 3 Bde deploy, there is always an FRG from the Fd Wksp allocated to the force ensuring that we have a better chance than most of getting operational service for our tradesmen.

One of the difficulties of the deployments has been that all the mundane but necessary work still requires someone's attention. Currently there are two of the four production Pls commanded by a SGT or WO2 with the Lt and Mdm Vehicle Pls once again combining. In addition to this there are numerous CFN/CPL stepping up one to two positions of responsibility and getting the job done, this says a lot of the character of our junior tradesmen.

As the only thing constant is change, we have been constantly changing the set-up of the Wksp so that the ASM, WO1 Peter Chalker can maximise the available floor space for production (to date; only the OC's office hasn't moved ... yet). In truth

who avoided all blame with the catch call 'I'm just an OJTer!'. We also adopted a new catch cry for the year of 'Take more!' from the movie 'Rocco - Self titled'.

All in all it's been an adventure. All the best to you all.  
*Arte et Marte,*

## GE SECTION

by Sgt Mick 'The Rock' Patman.

This year GE has been cogging along at full speed. Cpl Russ "fishing guide" Geelan-Ashcroft returned from East Timor in time for Ex Pred/Croc '03. Sgt Mick Patman arrived from 51 FNQR in Cairns and settled in at the helm. Cfn Brady 'Li'l Ron' White added a fresh face, as did Cpl Glen 'fingers' Kindness a bit of humour.

The old hands remained. Cfn Josh 'Big Toys' Lubke and Cfn Heath 'Care factor' Cardier. Josh is off to be 2 Cav Weld 2IC and Cards off to Pilbara to try out his new Marine skills. As usual the section fixed and manufactured it's way along from Exercise to Exercise (with a few fishing trips along the way). Two engineers (ring in OJTs) started fitting courses - SPR Smith and Brown, soon to be joining the brotherhood... Keepin' it real.

All in all a good crew to save the greasers pants in the field. A hard section... no fluffers needed.

## EIR Sect

With the year getting off to a late start sometime in mid February, the premier section of the workshop picked up the Christmas sag and ran with the 'Follow the sapper' (and pick up the pieces) motto.

With CPL Greg Jones being promoted out of the Elec CPL position it left a vacancy that CPL Jeremy 'Boong' Armstrong filled after a 12 month stint (that seemed like 12 years) at 1 AVN Regt. Also posted in this year was CFN Mick Gordon to replace CFN Richard 'Bubba' Kelly who left for greener (and colder) pastures in sunny Pucka. On the nerd side of the house CFN Darrin 'Dougie' Munday (or whatever the day of the week he actually wants to turn up) has stayed on in the CPL Radio Mech position. With the completion of SUB1CPL later this year should see him wearing the stripes for that position.

After a month at work Boong decided it would be nice to take a little trip across the Tasman to the land of the long white cloud (thanks Stretch!). A three month ANZAC Exchange was a surprise not only for me but my bank as well. I was sent to the 2nd Logistics Battalion Workshop located at Linton Military Camp approximately 150km north of Wellington. One of the coldest places they could find, but hey who's complaining! The reception I received in NZ was excellent and the hospitality I was shown was second to none. I was given plenty of time off to visit most of the country and sample everything NZ has to offer.

Gordo decided to turn up to work mid year after his second tour (or dash for cash) in East Timor to take over the reins whilst I was working hard in New Zealand. The end of this year will see Gordo leave the Regt and move to Townsville to take up

his new posting at 3CSSB. Gordo will be leaving us with his new wife Bec, who he wedded on the 29 August this year.

Dougie, well what can I say? If it wasn't for some of the ingenuity that Dougie comes up with, the Regt wouldn't

be able to watch movies on the side of a connex in the middle of the Mount Bundy Training Area. I suppose the Regt wouldn't have comms either, but sometimes that might not be a bad thing!

Showing the Regt how easy field can be is what we are all about. Dolby 5.1 Surround sound and wafting the smells of culinary masterpieces across a defensive position in the field is only just the tip of the iceberg.

Cheers to all.

*Arte et marte.* Boong

## 1 FIELD SQN FRT

by CPL Russ Geelan - Ashcroft.

1 Fd Sqn FRT was feeling a little thrown together for Predators Gallop as CPL Russ Geelan - Ashcroft returned from leave the morning the road party departed from Darwin and SGT Paul Kitching joined the FRT just prior to deploying in SWBTA after being away on Sub Two for WO. Cfn's Gavin Field, Sean Geaney and Matt Stevens did an excellent job getting the Sqn ready to deploy with the vehicles at 100% FF for the start of the exercise.

The first phase of the exercise involved support for troop training activities, involving mechanised training, route denial and clearance, Medium Girder Bridges (MGB) and Floating Support Bridges (FSB). The FSBs and Bridge Boat Erections (BBEs) kept Russ and Gav busy, while all of the VMs got sick of changing oil filter gaskets on the carriers.

CPL Gary Glasshoff put his spare time to good use and made a 'flash as a rat with a gold tooth' shitter before he seized the chainsaw. But that's another story. (Stevo just wants me to mention that as usual Stevo was amazing).

Russ went on a water recon with a couple of the Engineers, involving a 40km run up the coast. Going that far in Mk1 Assault Boats (60 years old) and 40 hp Johnson outboards (30 years old), could only be described as 'interesting', and muddy.

Meanwhile, back at the ranch, Cfn Clark Usher was changing a final drive assembly on a carrier that quite literally blew apart. The crew was lucky that the car speared off the road and went uphill - not down.

We had a short maintenance period when Stevo thought he'd do a bit of Ninnox driving (200km return). When they got to the croc (a carrier) they couldn't find the inside drive sprocket (buggered if we know where it went, was the crews response).

During this time we had Cfn Rice (OJT VM) and Cfn Williams (OJT Fitter) for a few days each, but eventually they were replaced by Cfn Sean Geaney (VM). Sean has managed to dig in and stay ever since. Sean says he's used to the back of the mog now. He can't sit in the front, Russ and Gav would have to move the stereo.

The war went fairly smoothly for the FRT. Gav and Sean had plenty of work on the FSB rafts the Engineers pushed around the coast (except when they were sitting on the mudflat waiting for the tide). The rest of the FRT have had plenty to do as well. Just before the main push Gary had to head home, so Clark went back to the eche-lon with the ARVL.

We are into a maintenance period now, before Croc '03, which is keeping the VMs pretty busy. Everyone is looking forward to a couple of days off in Rocky, then Croc and home in a few weeks.



## Positioned to Support



With its acquisition of GM Defense, General Dynamics Land Systems is now able to provide even greater support to the Australian Defence Force.

With a world-class manufacturing facility in Pooraka, South Australia, a maintenance facility in Darwin and a Logistics Centre opening in Brisbane, we're strategically positioned to provide logistics, support and production capability.

Our international research and development, coupled with local and regional facility presence, make us the premier choice for light armour in the Asian Pacific Rim. General Dynamics Land Systems is the global leader in light armoured vehicles. That's why it's the name you can trust for long-term, cost-effective products, service, training and support.

General Dynamics Land Systems-Australia, Pty. Ltd., Regional Headquarters,  
Level 23, 25 Grenfell Street, Adelaide, South Australia 5001 Phone: 08 8308 9400 Fax: 08 8308 9430  
Regional Marketing Office, Unit 16, 71 Constitution Avenue, Campbell ACT 2612  
Phone: 61 2 6257 7200 Fax: 61 2 6230 6933 [www.gm-defense.com](http://www.gm-defense.com) / [www.gdls.com](http://www.gdls.com)

**GENERAL DYNAMICS**  
Land Systems-Australia